



FUJITSU Server

PRIMEQUEST 3800B2

System Configuration Guide

July 2019 Ver. 2.0

Contents

1. Overview
 2. Base Unit
 3. System Board (SB)
 4. CPU
 5. Memory
 6. I/O Unit
 7. Disk Unit (DU)
 8. HDD / SSD in Disk Unit
 9. PSU for Base Unit, Power Cords for Base Unit
 10. PCI Cards
 11. Rack Installation
 12. Maximum Quantity of PCIe Cards
 13. Available OS
 14. Restrictions
- Change Report

1. Overview

July 2019 Ver. 2.0

Front side

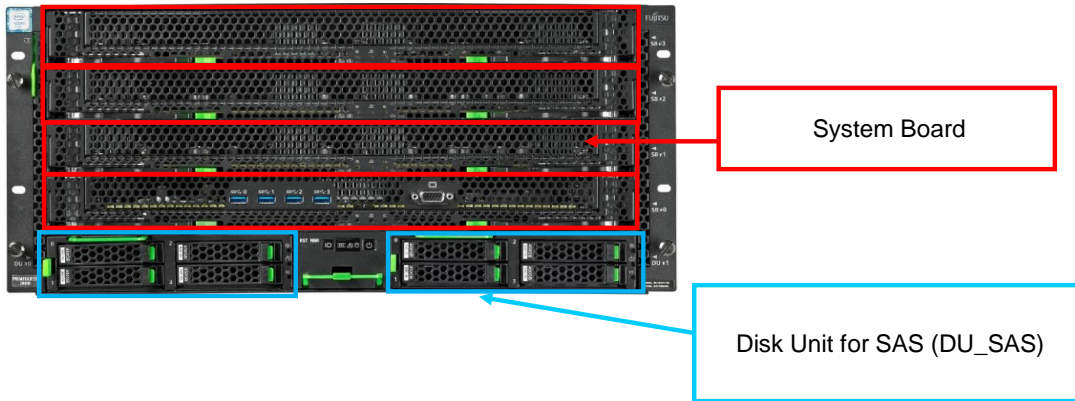

Rear side

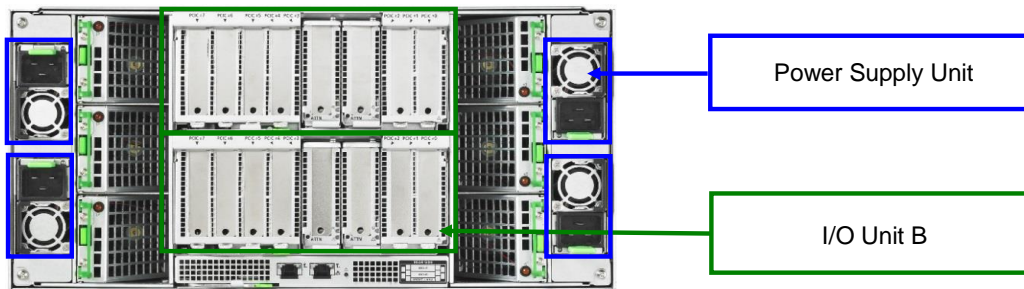

Configuration Diagram

July 2019 Ver. 2.0

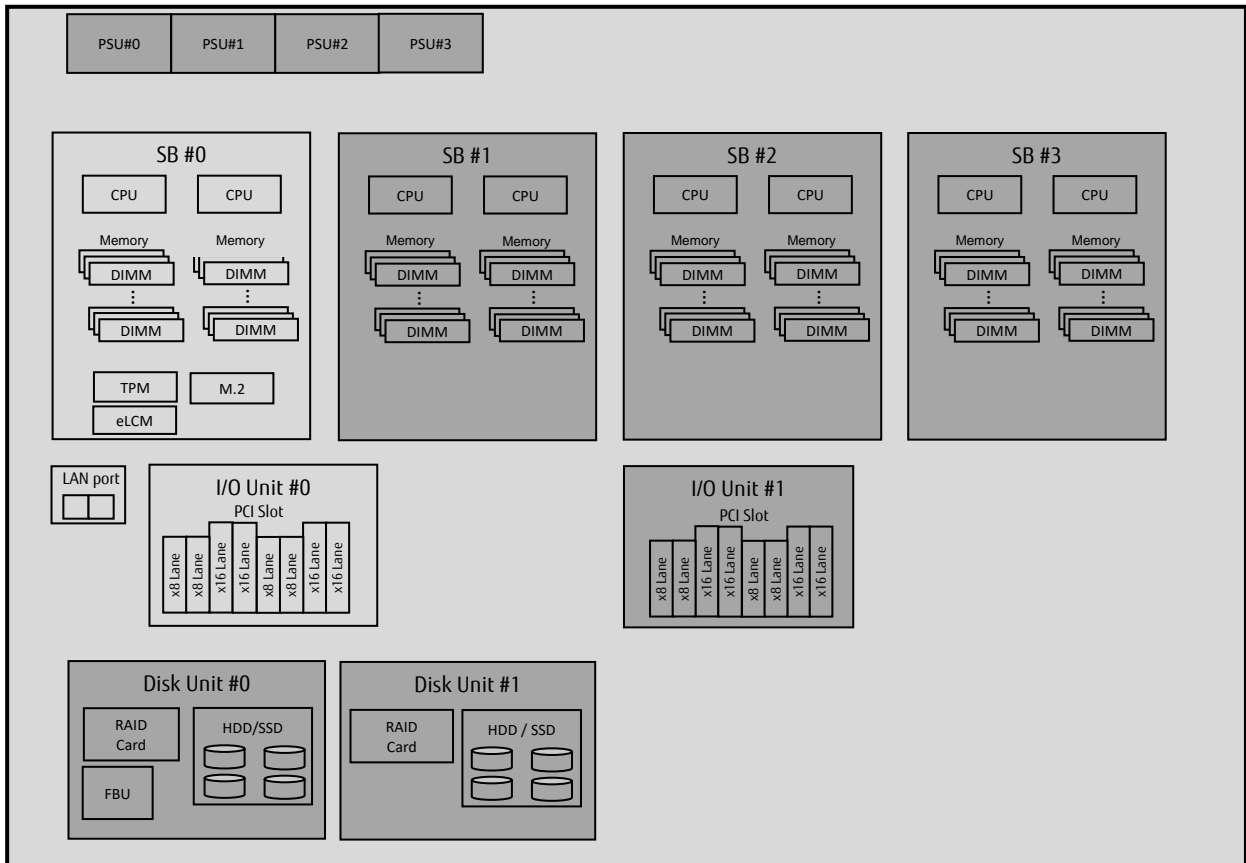

Light gray color components are included in Base Unit.
 Dark gray color components are optional.

2.Base Unit

July 2019 Ver. 2.0

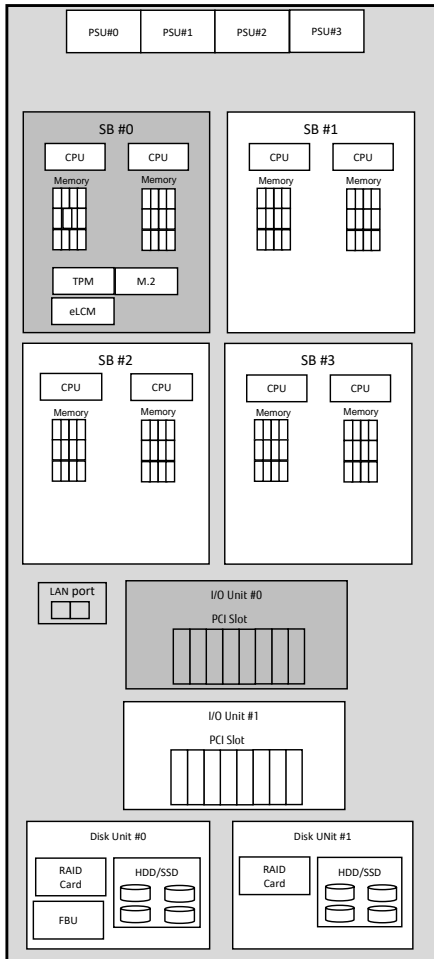

Part Numbers Legend:

Part numbers:

MC-***** is a Build-to-Order (BTO) option to be assembled with Base Unit

MCX***** is an option to be shipped separately from a Base Unit (Loose Delivery)

The following options are NOT included in the Base Unit.
 - CPU, Memory, PSU, power cord

The following components are included in the Base Unit.
 - 1x System Board
 - 1x I/O Unit
 - 1x Rack Mount Kit

PRIMEQUEST 3800B2 Base Unit

MCK3AC111B

- Rack mount type
- 1x System Board is included in the Base Unit, Max. 4x System Boards can be mounted.
- 1x I/O Unit is included in the Base Unit, Max. 2x I/O Units can be mounted.
- PCI Boxes cannot be connected.
- 1x Management LAN
- 1x 1GbE (RJ45) (Shared LAN)
- PSUs need to be ordered, Max. 4x PSUs can be mounted.
- 6x Fan units are included in the Base Unit with redundancy.
- Power cords need to be ordered. The quantity is equal to the quantity of PSU.
- Rack space : 5U

Advanced Thermal Design Option

MC-0PTH2

Operating temperature of up to 40°C

When this option is selected, CPUs exceeding 165W can not be installed.

→ System Board

3. System Board

July 2019 Ver. 2.0

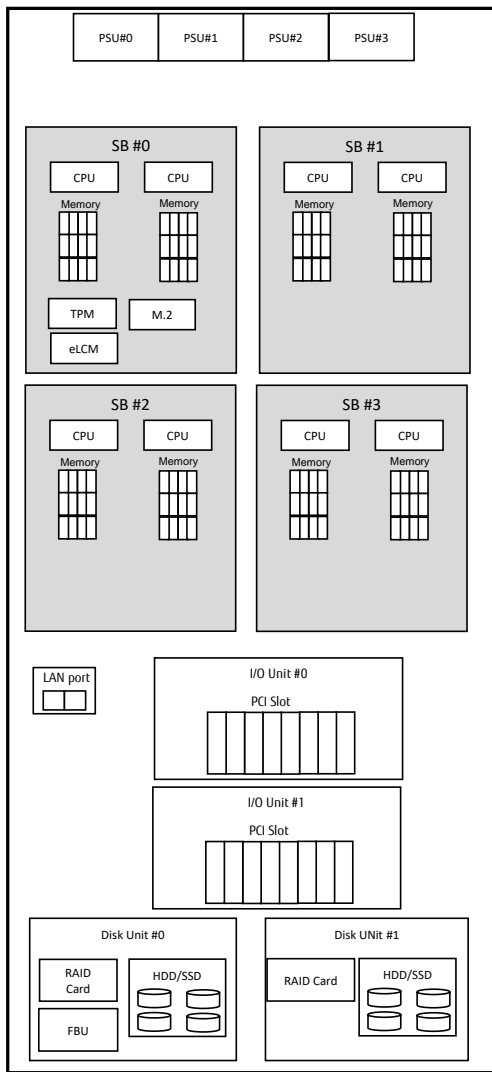

1x System Board is included in the Base Unit.
Max. 4x System Boards can be mounted per Base Unit.

System Board
MC-3HSBD1B / MCX3HSBD1B (LD)

- The System Board does not include a security chip called TPM.
- Neither CPU nor memory module is included. CPU and memory need to be ordered separately.
- 2 x CPUs and min. 2 x memory modules (4 x DIMMs) need to be mounted per System Board.
- Max. 12 x memory modules (24 x DIMMs) can be mounted.

The following options can be installed only in System Board #0.

eLCM Activation License (no load)
MC-6KMA11 / MCX6KMA11 (LD)

- For PRIMEQUEST 3800B2
- One License per system

TPM module V2.0
MC-6HTP31 / MCX6HTP31(LD)

- Available except for China
- One for System Board

→ USB Flash Device & M.2 Flash Device

Available combination of CPU and memory per System Board

		Number of CPU	
		1	2
Memory in units of two DIMMs	1	C	C
	2	C	A
	3	C	B
	~	C	B
	12	C	B

A : The combination is available. The quantity of memory is the minimum quantity.
B : The combination is available.
C : The combination is NOT available.
* 2x CPUs need to be mounted on each System Board.

USB Flash Device & M.2 Flash Device

July 2019 Ver. 2.0

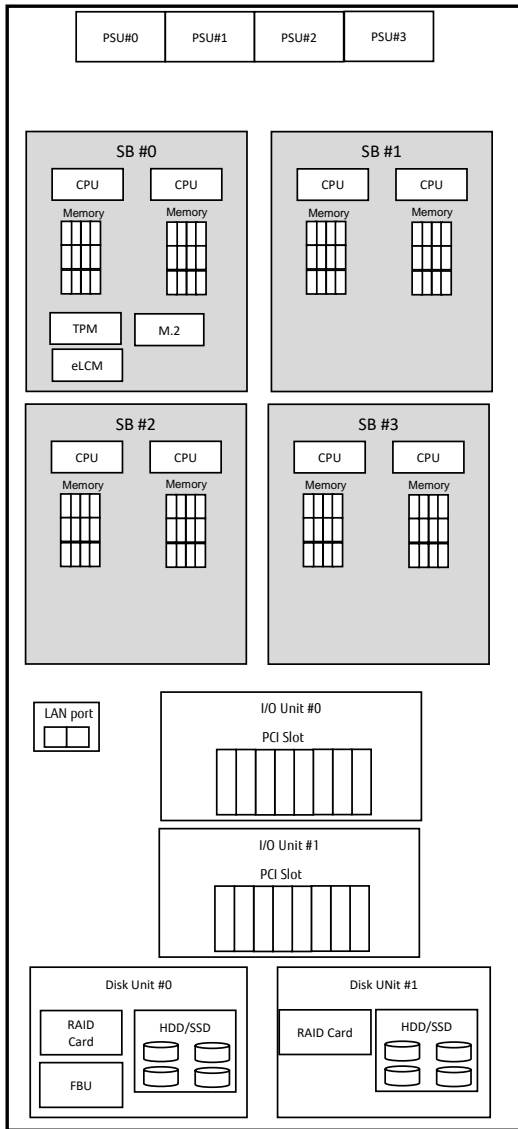

Only one type of the following options can be installed on System Board #0 only.

USB Flash Device 64GB Dual

MC-5FA411 / MCX5FA411(LD)

- 2x 64GB micro SD card, HW mirrored
- Cannot be mounted with MC*5FB751

M.2 Flash Device (VMware, 240GB)

MC-5FB741 / MCX5FB741 (LD)

- M.2 SATA 240GB for VMware boot only
- 1 x M.2 Flash Devices can be mounted.
- DWPD : 1.5

M.2 Flash Device 480GB

MC-5FB771 / MCX5FB771 (LD)

- M.2 SATA 480GB except VMware
- Max 2 x M.2 Flash Device can be mounted.
- DWPD : 1.5
- Cannot be mounted with MC*5FA411

M.2 Flash Device 240GB

MC-5FB751 / MCX5FB751 (LD)

- M.2 SATA 240GB except VMware
- Max 2 x M.2 Flash Device can be mounted.
- DWPD : 1.5
- Cannot be mounted with MC*5FA411

CPU

4.CPU

July 2019 Ver. 2.0

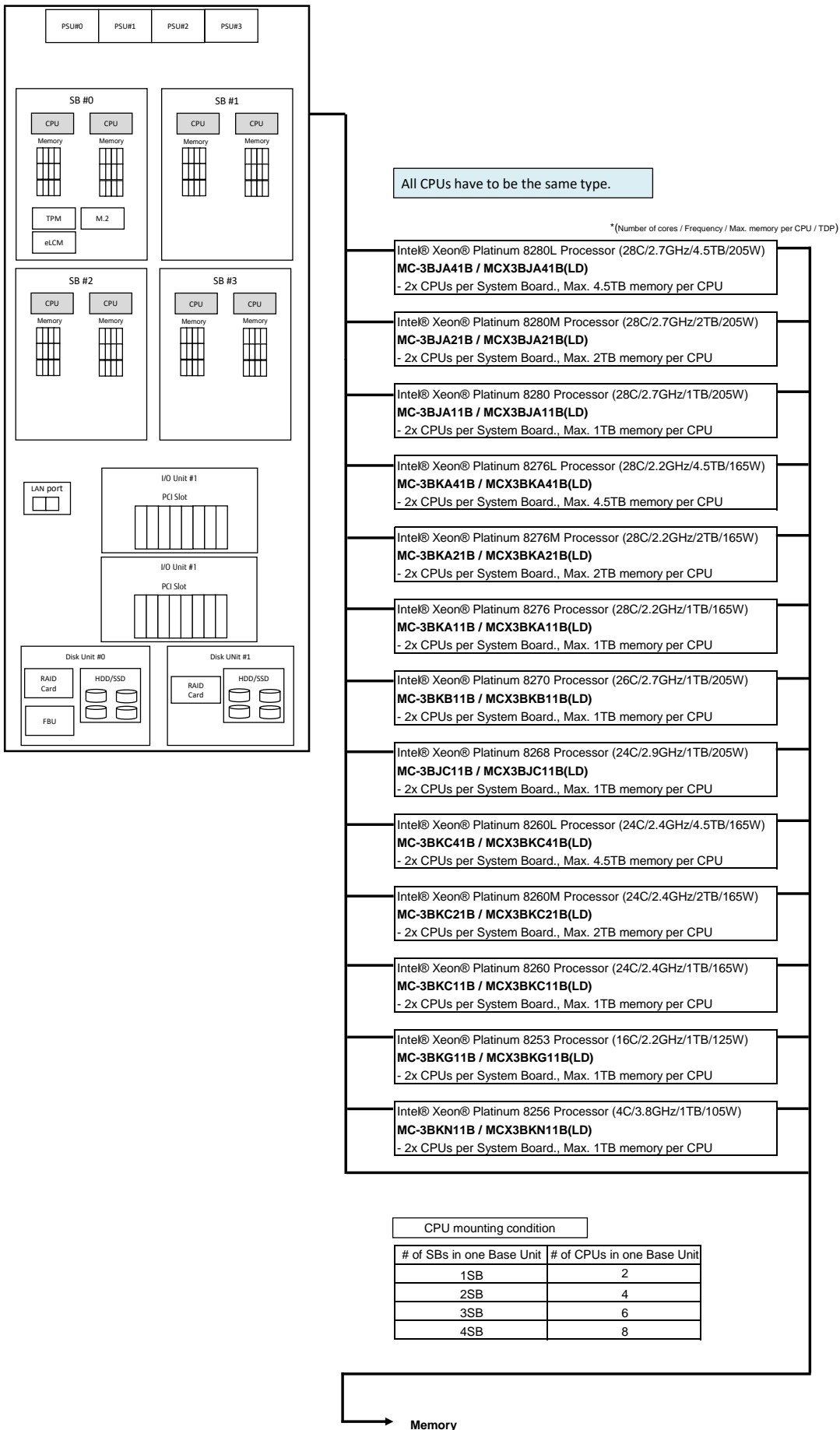

5.Memory

July 2019 Ver. 2.0

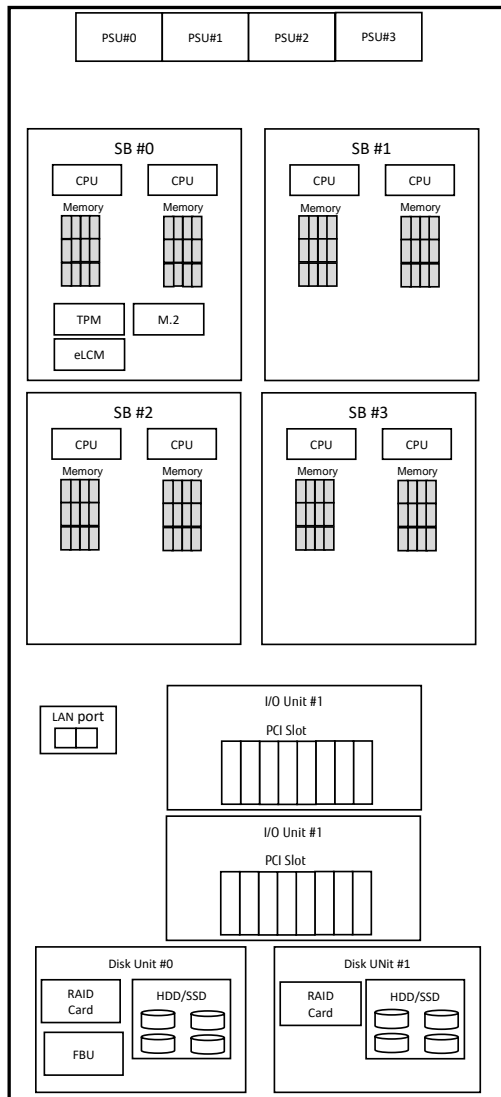

At least one option needs to be mounted per CPU.

32GB memory (16GB 1Rx4 DDR4 RDIMM x2)
MC-3CE611B / MCX3CE611B (LD)
 - Min. 1x Memory module (2 x DIMMs) needs to be mounted per CPU.
 - Max. 6x Memory modules (12 x DIMMs) can be mounted per CPU.
 - 2x 16GB 2933MHz 1Rx4 RDIMMs

64GB memory (32GB 2Rx4 DDR4 RDIMM x2)
MC-3CE711B / MCX3CE711B (LD)
 - Min. 1x Memory module (2 x DIMMs) needs to be mounted per CPU.
 - Max. 6x Memory modules (12 x DIMMs) can be mounted per CPU.
 - 2x 32GB 2933MHz 2Rx4 RDIMMs

128GB memory (64GB 2Rx4 DDR4 RDIMM x2)
MC-3CE811B / MCX3CE811B (LD)
 - Min. 1x Memory module (2 x DIMMs) needs to be mounted per CPU.
 - Max. 6x Memory modules (12 x DIMMs) can be mounted per CPU.
 - 2x 64GB 2933MHz 2Rx4 RDIMMs

128GB memory (64GB 4Rx4 DDR4 LRDIMM x2)
MC-3CE821B / MCX3CE821B (LD)
 - Min. 1x Memory module (2 x DIMMs) needs to be mounted per CPU.
 - Max. 6x Memory modules (12 x DIMMs) can be mounted per CPU.
 - 2x 64GB 2933MHz 4Rx4 LRDIMMs

256GB memory (128GB 8Rx4 DDR4 LRDIMM 3DS x2)
MC-3CE911B / MCX3CE911B (LD)
 - Min. 1x Memory module (2 x DIMMs) needs to be mounted per CPU.
 - Max. 6x Memory modules (12 x DIMMs) can be mounted per CPU.
 - 2x 128GB 2933MHz 8Rx4 3DS-LRDIMMs

512GB memory (256GB 8Rx4 DDR4 LRDIMM 3DS x2)
MC-3CEA11B / MCX3CEA11B (LD)
 - Min. 1x Memory module (2 x DIMMs) needs to be mounted per CPU.
 - Max. 6x Memory modules (12 x DIMMs) can be mounted per CPU.
 - 2x 356GB 2933MHz 8Rx4 3DS-LRDIMMs

* 256GB 8R LRDIMM can not be installed on a CPU with a memory limit of 1TB.



Memory 2

July 2019 Ver. 2.0

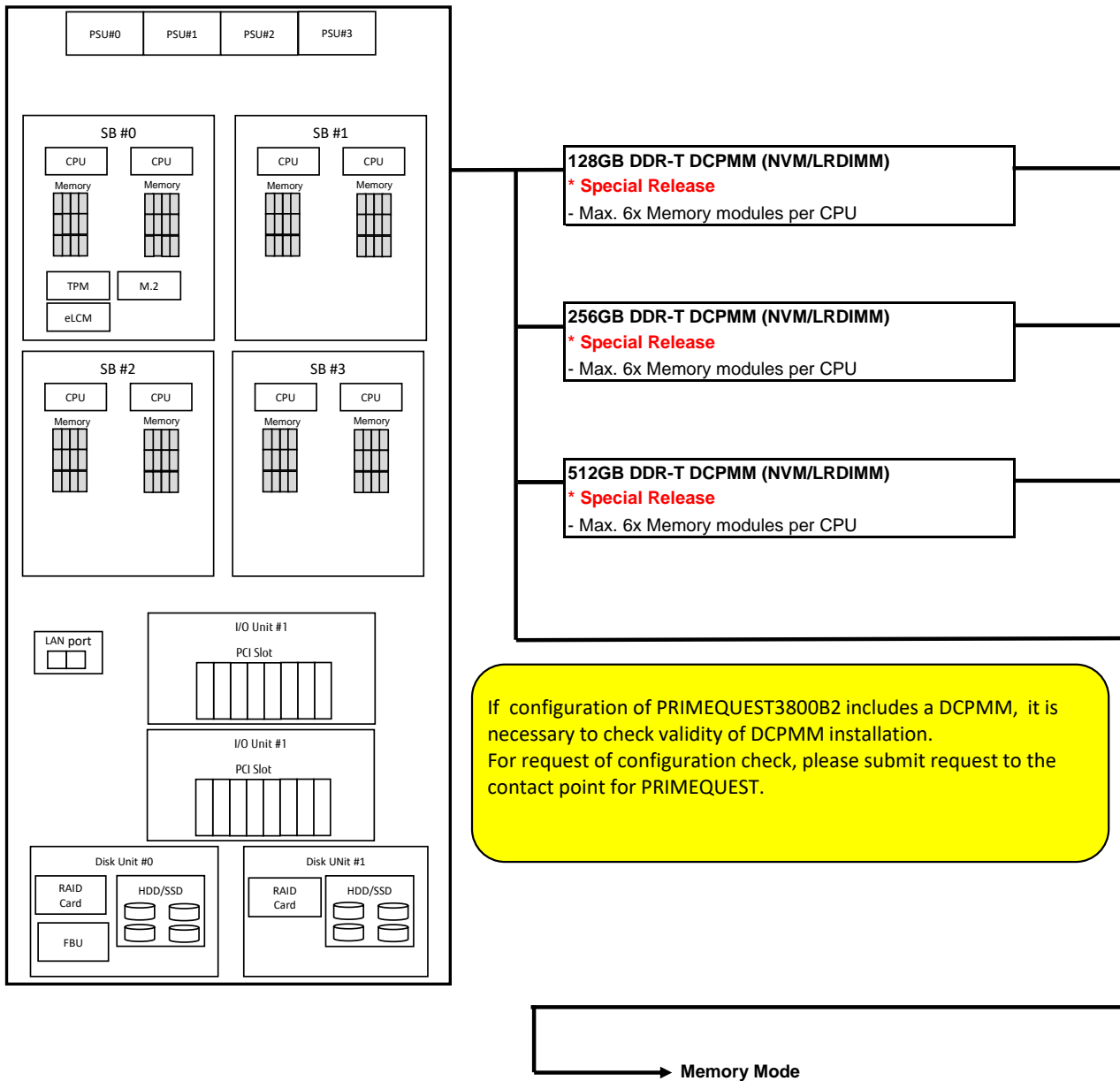

Memory Mode

July 2019 Ver. 2.0

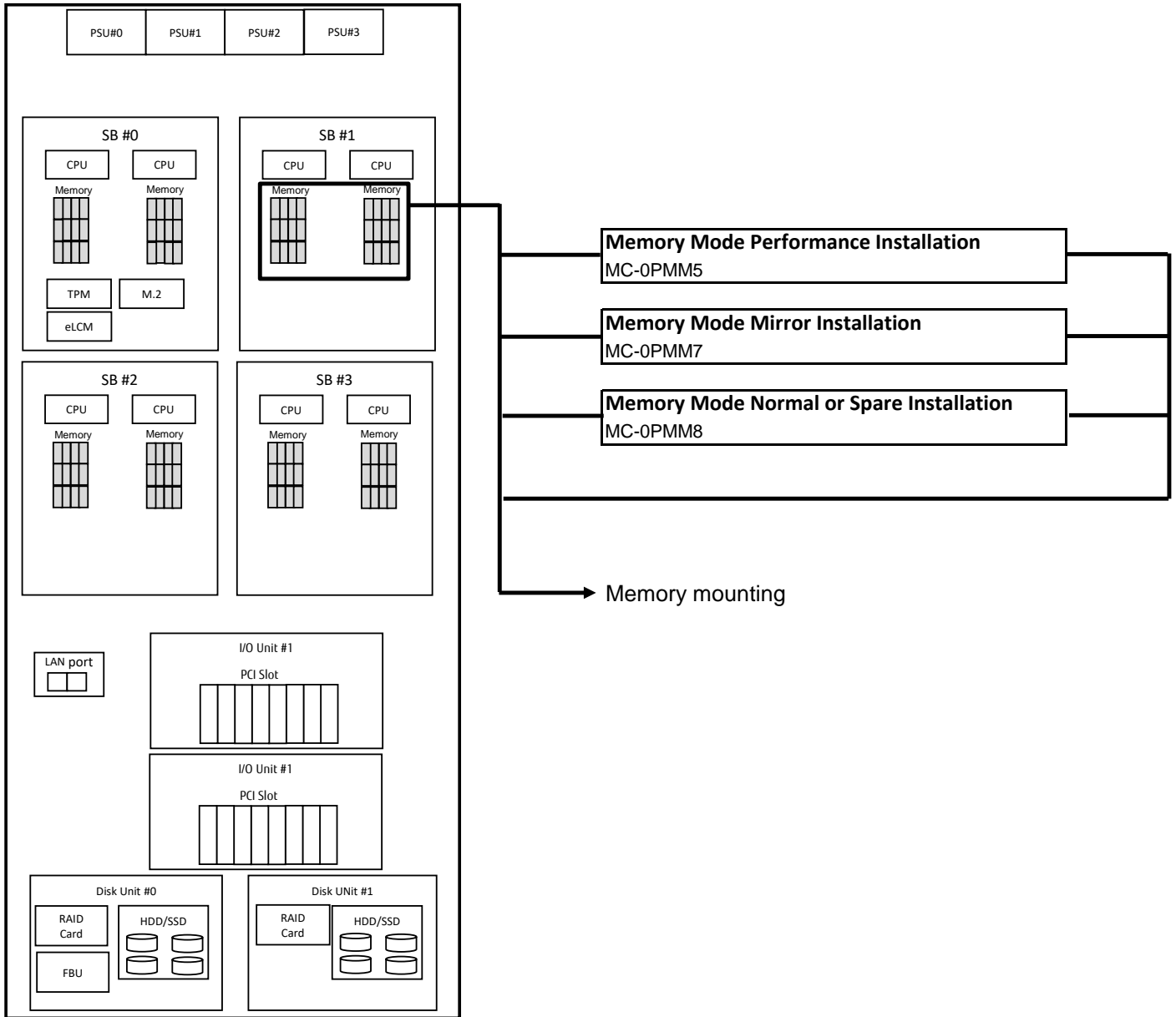

When DCPMMs are installed, Memory Mode is limited. The following table shows the details.

Memory Mode of Albireo	Support	DCPMM Mode		
		Memory Mode	App Direct Mode	Memory Mode + App Direct Mode
Normal	Yes	Supported	Supported	Supported
Full Mirror	Yes	Not Supported	Supported	Supported
Address Range Mirror	Yes	Not Supported	Supported	Supported
Spare	No	Not Supported	Not Supported	Not Supported

Memory Mounting 1

July 2019 Ver. 2.0

1. Memory

- (1) Memory module for PRIMEQUEST is composed of 2 x DIMMs.
- (2) At least 2 DIMMs have to be installed in one CPU (4 DIMMs in one SB) in Normal mode and Spare mode, 4 DIMMs have to be installed in one CPU (8 DIMMs in one SB) in Mirror mode.
- (3) Up to 12 DIMMs can be installed in each CPU.

2. Memory Mounting Conditions

- (1) A mixture of different type of memory is not possible in the system.
The exception is a combination of 16GB RDIMM and 32GB RDIMM, which is possible to mix in the system.
- (2) Units of memory expansions : One set (2 DIMMs) for one CPU in Normal Mode and Spare Mode, 2 sets (4 DIMMs) for one CPU in Mirror Mode.

3. Memory Support for Operating Systems of PRIMEQUEST 3800B2

Operating System	Max. Memory Capacity (TB)
Microsoft® Windows Server® 2016 (Standard / Datacenter) Microsoft® Hyper-V Server 2016	3
Microsoft® Windows Server® 2019 (Standard / Datacenter) Microsoft® Hyper-V Server 2019	3
Red Hat® Enterprise Linux® 7	12
SUSE® Linux Enterprise Server 12	24
SUSE® Linux Enterprise Server 15	24
VMware vSphere® 6.5	4
VMware vSphere® 6.7	4

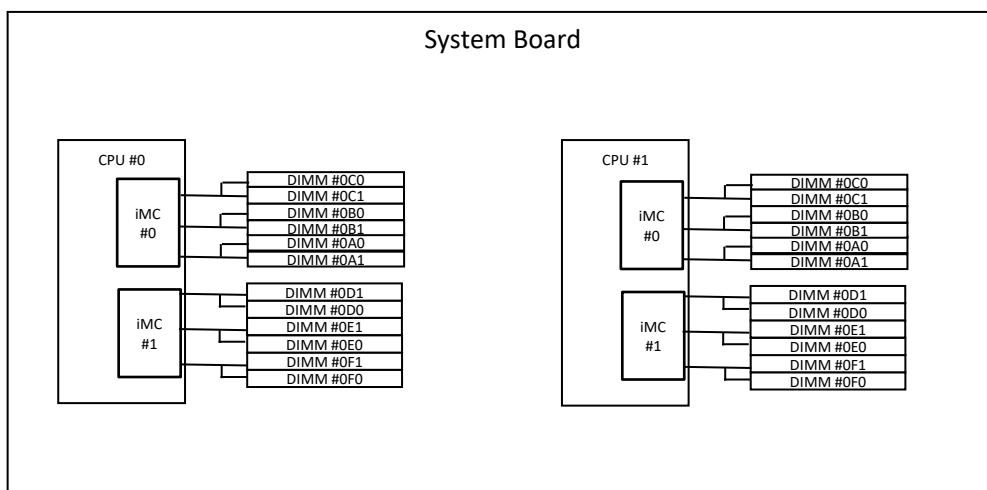

➔ **Memory Mounting 2**

Memory Mounting 2

July 2019 Ver. 2.0

DIMM mounting order on System Board

DDR4 DIMM installation order

The order of DIMM installation is shown in the following table. DIMMs are installed in order from one with small number.

		CPU#0						CPU#1						
		iMC#0			iMC#1			iMC#0			iMC#1			
		0A0	0B0	0C0	0D0	0E0	0F0	1A0	1B0	1C0	1D0	1E0	1F0	
		0A1	0B1	0C1	0D1	0E1	0F1	1A1	1B1	1C1	1D1	1E1	1F1	
Normal	Disabled	1	2	4 (*1), 8	1	2	4 (*1), 8	1	3	5 (*1), 9	1	3	5 (*1), 9	(*3)
	Enabled	6	6 (*2)	10	6	6 (*2)	10	7	7 (*2)	11	7	7 (*2)	11	(*3)
Spare	Disabled	1	4	8	2	6	10	1	5	9	3	7	11	(*3)
	Enabled	1	4	8	2	6	10	1	5	9	3	7	11	
Full Mirror/ Address Range Mirror	Disabled	1	1	4	1	1	4	1	1	5	1	1	5	
		2	2	4	2	2	4	3	3	5	3	3	5	
	Enabled (768GB CPU)	1	1	2	1	1	2	1	1	3	1	1	3	(*4)
		-	-	-	-	-	-	-	-	-	-	-	-	-

(*1)(*2) In the case of four DIMMs in iMC, remove DIMM installed in (*1) slot and then install DIMM to (*2) slot.

(*3) When the CPU which memory capacity is 768GB is installed, 128GB DIMM can be installed up to number 5 and cannot be installed after number 6.

(*4) Only when the CPU which memory capacity is 768GB and 128GB DIMM are installed together, this installation order is applied.

Memory Mixed Condition

July 2019 Ver. 2.0

Which size of DIMM can be installed together in a DDR CH or an SB are shown in the following tables.

The type of the DIMM mixed installation condition for each DIMM.

	16GB 1R RDIMM	32GB 2R RDIMM	64GB 2R RDIMM	64GB 4R LRDIMM	128GB 8R LRDIMM (3DS)	256GB 8R LRDIMM (3DS)
16GB 1R RDIMM □	-	YES (*1)	YES (*1)			
32GB 2R RDIMM	YES (*1)	-	YES (*1)			
64GB 2R RDIMM	YES (*1)	YES (*1)	-			
64GB 4R LRDIMM				-		
128GB 8R LRDIMM (3DS)					-	YES
256GB 8R LRDIMM (3DS)					YES	-

YES: Mixable in DDR CH/SB

Blank: Not Mixable in DDR CH/SB

"-": Same DIMM

(*1) When RDIMM or LRDIMM other than 3DS with different rank number is populated together within a DDR channel, the DIMM with largest rank number must be populated at far side and the DIMM with smallest rank number must be populated at near side.

Mixable conditions

	Yes (Mixable in DDR CH)	"-" (Mixable in DDR CH)	Blank (Not Mixable in Partition)
DDR CH	YES	YES	
SB	YES	YES	
System	YES	YES	

YES: Mixable in DDR CH/SB/System.

Blank: Not mixable in DDR CH/SB/System.

Memory Mixed Installation Condition

July 2019 Ver. 2.0

DIMM mixed installation conditions are shown in the following table.
 Same symbols mean that same DIMMs can be installed which is defined in the table below.
 Different symbols mean that different DIMMs can be mixed.

DIMM mixed installation condition.

Memory Mode	Lockstep	CPU#0						CPU#1					
		iMC#0			iMC#1			iMC#0			iMC#1		
		0A0	0B0	0C0	0D0	0E0	0F0	0A0	0B0	0C0	0D0	0E0	0F0
Normal	Disabled	□	△	○	☆	▽	◇	■	▲	●	★	▼	◆
		♠	♥	♣	♞	♟	♚	♠	♟	♣	♞	♟	♚
	Enabled	□	△	○	☆	▽	◇	■	▲	●	★	▼	◆
		♠	♥	♣	♞	♟	♚	♠	♟	♣	♞	♟	♚
Sparing	Disabled	□	△	○	☆	▽	◇	■	▲	●	★	▼	◆
		♠	♥	♣	♞	♟	♚	♠	♟	♣	♞	♟	♚
	Enabled	Not Supported											
Full Mirror (Mirror Keep) / Address Range Mirror	Disabled	□	□	□	△	△	△	■	■	■	▲	▲	▲
		○	○	○	☆	☆	☆	●	●	●	★	★	★
	Enabled	Not Supported											
Full Mirror (Capacity Keep)	Disabled	□	□	□	□	□	□	□	□	□	□	□	□
		□	□	□	□	□	□	□	□	□	□	□	□
	Enabled	Not Supported											

Mixing condition shown contains installation conditions about near side and far side in DDR CH.
 When RDIMM or LRDIMM other than 3DS with different rank number is populated together within a DDR channel, the DIMM with largest rank number must be populated at far side and the DIMM with smallest rank number must be populated at near side.

DCPMM(NVM/LRDIMM) installation pattern

July 2019 Ver. 2.0

At least one AEP DIMMs have to be installed in one CPU.

Up to 6 AEP DIMMs can be installed in one CPU.

DCPMM increment unit is one unit. If DCPMM is installed, DDR4 DIMM increment unit is one unit.

The following table shows the installation pattern of DDR4 DIMMs and DCPMMs.

DCPMM installation pattern within CPU

Mode	Pattern	CPU#0						Remark
		iMC#0			iMC#1			
		OA0	OB0	OC0	OD0	OE0	OF0	
		OA1	OB1	OC1	OD1	OE1	OF1	
AD	2-2-2	DRAM1	DRAM1	DRAM1	DRAM1	DRAM1	DRAM1	(*1) Symmetric
		DCPMM1	DCPMM1	DCPMM1	DCPMM1	DCPMM1	DCPMM1	Any DRAM
MM	2-2-2	DRAM1	DRAM1	DRAM1	DRAM1	DRAM1	DRAM1	(*1) Symmetric
		DCPMM1	DCPMM1	DCPMM1	DCPMM1	DCPMM1	DCPMM1	Any DRAM
AD+MM	2-2-2	DRAM3	DRAM3	DRAM3	DRAM3	DRAM3	DRAM3	(*1) Symmetric
		DCPMM1	DCPMM1	DCPMM1	DCPMM1	DCPMM1	DCPMM1	Except for 3DS LRDIMM
AD	2-1-1	DRAM1	DRAM1	DRAM1	DRAM1	DRAM1	DRAM1	(*1) Symmetric
		DCPMM1	-	-	DCPMM1	-	-	Any DRAM
MM	2-1-1	DRAM2	DRAM2	DRAM2	DRAM2	DRAM2	DRAM2	(*1) Symmetric
		DCPMM1	-	-	DCPMM1	-	-	RDIMM only (16 or 32GB)
AD+MM	2-1-1	DRAM3	DRAM3	DRAM3	DRAM3	DRAM3	DRAM3	(*1) Symmetric
		DCPMM1	-	-	DCPMM1	-	-	Except for 3DS LRDIMM
AD	2-2-1	DRAM1	DRAM1	DRAM1	DRAM1	DRAM1	DRAM1	(*1) Symmetric
		DCPMM1	DCPMM1	-	DCPMM1	DCPMM1	-	Any DRAM
MM	2-2-1	DRAM1	DRAM1	DRAM1	DRAM1	DRAM1	DRAM1	(*1) Symmetric
		DCPMM1	DCPMM1	-	DCPMM1	DCPMM1	-	Any DRAM
AD+MM	2-2-1	DRAM3	DRAM3	DRAM3	DRAM3	DRAM3	DRAM3	(*1) Symmetric
		DCPMM1	DCPMM1	-	DCPMM1	DCPMM1	-	Except for 3DS LRDIMM

Mode	DDR4 Type	Capacity
DRAM1	RDIMM	Any Capacity
	3DS LRDIMM	
	LRDIMM	
	3DS LRDIMM	
DRAM2	RDIMM	16GB or 32GB
	-	
	-	
DRAM3	RDIMM	Any Capacity
	3DS LRDIMM	
	LRDIMM	
	-	
DCPMM1	-	Any Capacity

AD: App Direct Mode

MM: Memory Mode (100%)

AD+MM: Memory Mode (Except for 100%)

(*1) Symmetric Population across all CPU.

If configuration of PRIMEQUEST3800B2 includes a DCPMM, it is necessary to check validity of DCPMM installation. For request of configuration check, please submit request to the contact point for PRIMEQUEST.

6.I/O Unit

July 2019 Ver. 2.0

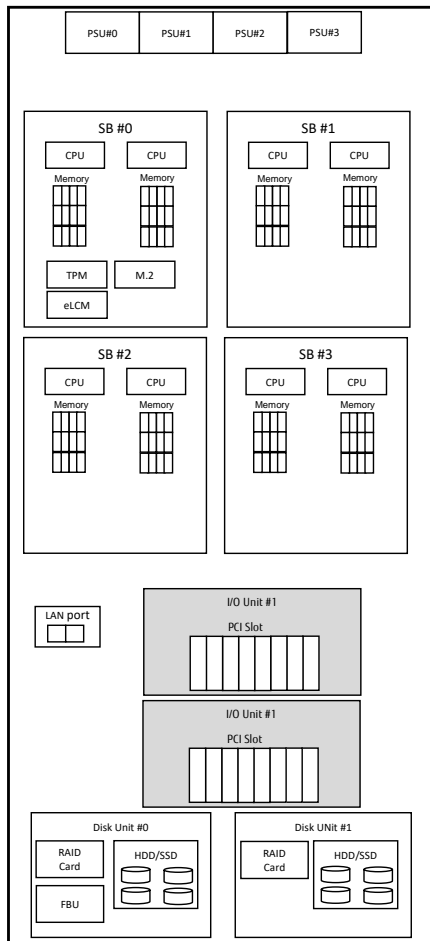

I/O Unit B

1x I/O Unit B is included in the Base Unit.
Max. 2x I/O Unit B can be mounted per Base Unit.

I/O Unit B
MC-3HUX61B / MCX3HUX61B (LD)
 - 1x I/O Unit B is included in the Base Unit.
 - Max. 2x I/O units can be mounted.
 - 8x PCIe slots Low Profile (4 slots are useable by one SB installed):
 2x PCIe Gen3 16Lane
 2x PCIe Gen3 16Lane (hot pluggable slots)
 4x PCIe Gen3 8Lane

Disk Unit

PCIe connection of PRIMEQUEST 3800B between SB, I/O Unit and Disk Unit.

		SB#0		SB#1		SB#2		SB#3	
		CPU#0	CPU#1	CPU#0	CPU#1	CPU#0	CPU#1	CPU#0	CPU#1
I/O Unit B#0	Slot#0	8Lane	enabled						
	Slot#1	8Lane	enabled						
	Slot#2	16Lane hotplug		enabled					
	Slot#3	16Lane hotplug		enabled					
	Slot#4	8Lane			enabled				
	Slot#5	8Lane			enabled				
	Slot#6	16Lane			enabled				
I/O Unit B#1	Slot#7	16Lane			enabled				
	Slot#0	8Lane				enabled			
	Slot#1	8Lane				enabled			
	Slot#2	16Lane hotplug					enabled		
	Slot#3	16Lane hotplug					enabled		
	Slot#4	8Lane						enabled	
	Slot#5	8Lane						enabled	
Slot#6	16Lane						enabled		
Slot#7	16Lane							enabled	
Disk Unit#0			enabled						
Disk Unit#1					enabled				

7. Disk Unit

July 2019 Ver. 2.0

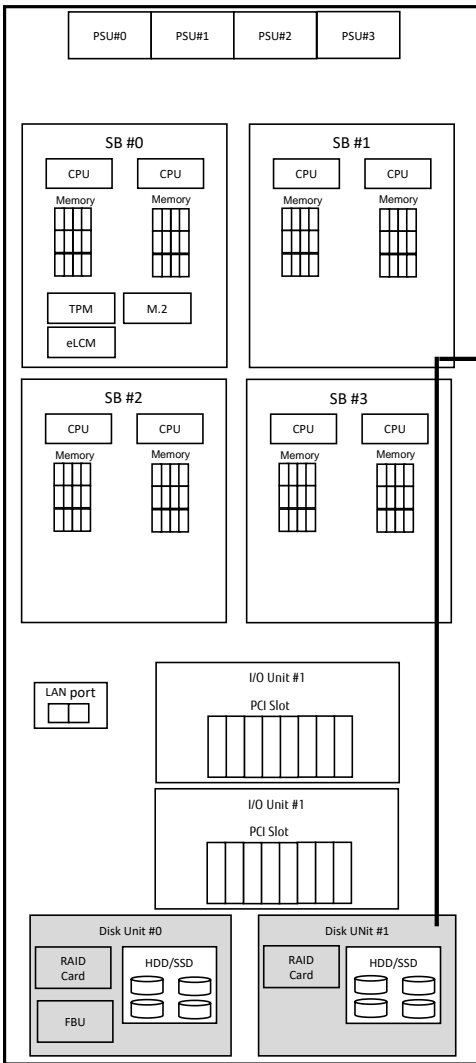

Disk Unit

Max. 2x Disk Units can be mounted per Base Unit.

Disk Unit for SAS (DU_SAS)
MC-5HDU31B / MCX5HDU31B (LD)
 - Max. 2x Disk Units per Base Unit.
 - 1x RAID Controller card per Disk Unit needs to be mounted.
 - Max 4x HDD/SSD can be mounted per Disk Unit.

Option for Disk Unit SAS (DU_SAS)

SAS RAID Controller Card (EP420i)
MC-0JSRA1 / MCX0JSRA1 (LD)
 - One RAID Controller card enables to mount 4x disk drives such as HDD or SSD.
 - 12Gbps for each disk drive. 2GB of cache memory
 - RAID 0/1/1E/5/6/10 and hot spare supported

Flash Back-up Unit
MC-0JFB61 / MCX0JFB61 (LD)
 - Flash Backup Unit for RAID Controller EP420i with cache memory.

RAID Advanced Software Options
MC-0KLA51 / MCX0KLA51 (LD)
 License Activation Key for CacheCade 2.0 for PRAID EP420i / 420e

SAS RAID Controller Card (EP540i)
MC-0JSR71 / MCX0JSR71 (LD)
 - One RAID Controller card enables to mount 4x disk drives such as HDD or SSD.
 - 12Gbps for each disk drive. 4GB of cache memory
 - RAID 0/1/1E/5/6/10 and hot spare supported

Flash Back-up Unit for EP5x0i
MC-0JFB41 / MCX0JFB41 (LD)
 - Flash Backup Unit for RAID Controller EP540i/EP580i with cache memory.

SAS RAID Controller Card (EP580i)
MC-0JSR81 / MCX0JSR81 (LD)
 - One RAID Controller card enables to mount 4x disk drives such as HDD or SSD.
 - 12Gbps for each disk drive. 8GB of cache memory
 - RAID 0/1/1E/5/6/10 and hot spare supported

Flash Back-up Unit for EP5x0i
MC-0JFB41 / MCX0JFB41 (LD)
 - Flash Backup Unit for RAID Controller EP540i/EP580i with cache memory.

Disc Unit (PCIe SFF)

8.HDD

July 2019 Ver. 2.0

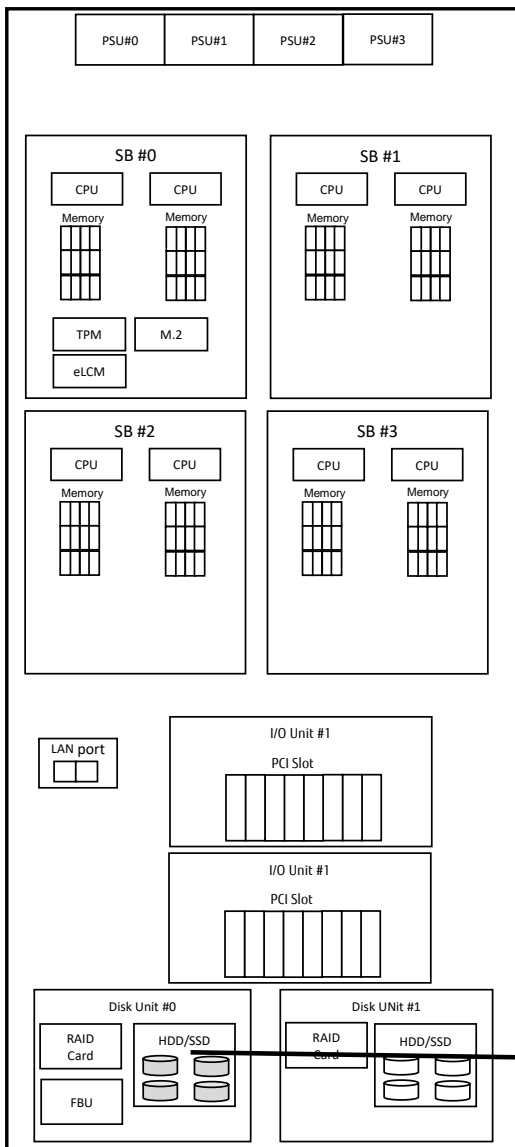

SAS RAID Controller Card is necessary to mount internal HDD or SSD.

300GB Hard Disk Drive (512n/12Gbps/15,000rpm)
MC-5DS771 / MCX5DS771 (LD)
 - SAS 12Gbps, hot plug, 512n format

600GB Hard Disk Drive (512n/12Gbps/15,000rpm)
MC-5DS961 / MCX5DS961 (LD)
 - SAS 12Gbps, hot plug, 512n format

900GB Hard Disk Drive (512n/12Gbps/15,000rpm)
MC-5DSA51 / MCX5DSA51 (LD)
 - SAS 12Gbps, hot plug, 512n format

300GB Hard Disk Drive (512n/12Gbps/10,000rpm)
MC-5DS781 / MCX5DS781 (LD)
 - SAS 12Gbps, hot plug, 512n format

600GB Hard Disk Drive (512n/12Gbps/10,000rpm)
MC-5DS971 / MCX5DS971 (LD)
 - SAS 12Gbps, hot plug, 512n format

900GB Hard Disk Drive (512n/12Gbps/10,000rpm)
MC-5DSA61 / MCX5DSA61 (LD)
 - SAS 12Gbps, hot plug, 512n format

1.2TB Hard Disk Drive (512n/12Gbps/10,000rpm)
MC-5DSB41 / MCX5DSB41 (LD)
 - SAS 12Gbps, hot plug, 512n format

1.8TB Hard Disk Drive (512e/12Gbps/10,000rpm)
MC-5DSC21 / MCX5DSC21 (LD)
 - SAS 12Gbps, hot plug, 512e format

2.4TB Hard Disk Drive (512e/12Gbps/10,000rpm)
MC-5DSD11 / MCX5DSD11 (LD)
 - SAS 12Gbps, hot plug, 512e format

→ SSD

8.SSD

July 2019 Ver. 2.0

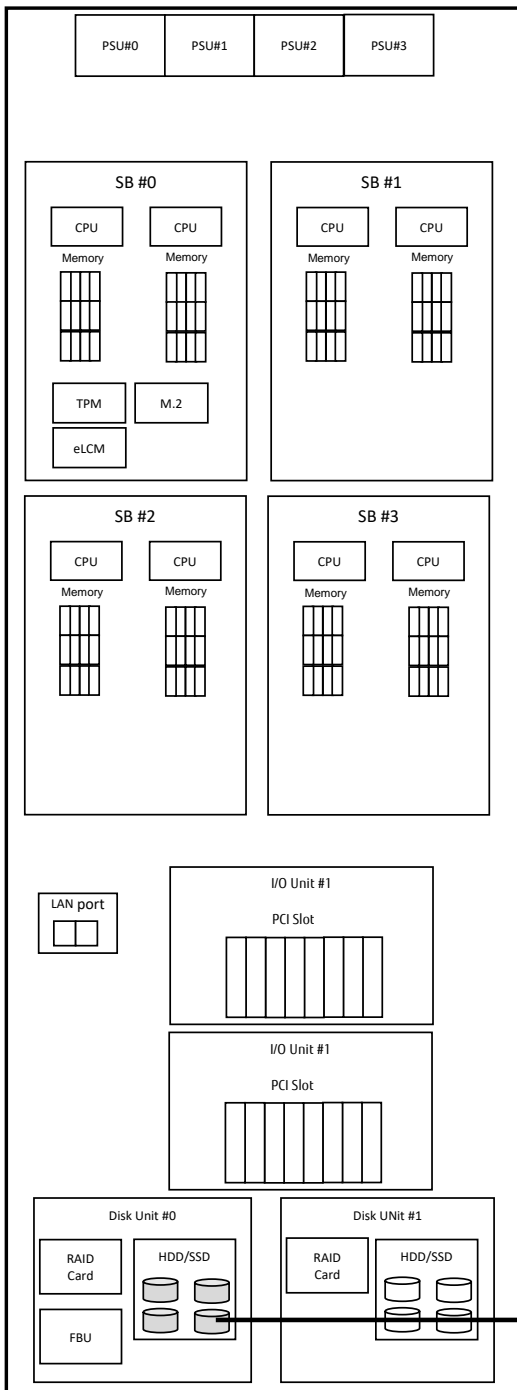

SAS RAID Controller Card is necessary to mount internal HDD or SSD.

400GB Solid State Drive (512n / 12Gbps / 10DWPD)
MC-5DG821 / MCX5DG821 (LD)
 - SAS 12Gbps, MLC, hot plug, DWPD: 10

800GB Solid State Drive (512n / 12Gbps / 10DWPD)
MC-5DG921 / MCX5DG921 (LD)
 - SAS 12Gbps, MLC, hot plug, DWPD: 10

1.6TB Solid State Drive (512n / 12Gbps / 10DWPD)
MC-5DGA21 / MCX5DGA21 (LD)
 - SAS 12Gbps, MLC, hot plug, DWPD: 10

400GB Solid State Drive (512n / 12Gbps / 3DWPD)
MC-5DH821 / MCX5DH821 (LD)
 - SAS 12Gbps, MLC, hot plug, DWPD: 3

800GB Solid State Drive (512n / 12Gbps / 3DWPD)
MC-5DH921 / MCX5DH921 (LD)
 - SAS 12Gbps, MLC, hot plug, DWPD: 3

1.6TB Solid State Drive (512n / 12Gbps / 3DWPD)
MC-5DHA21 / MCX5DHA21 (LD)
 - SAS 12Gbps, MLC, hot plug, DWPD: 3

3.2TB Solid State Drive (512n / 12Gbps / 3DWPD)
MC-5DHB21 / MCX5DHB21 (LD)
 - SAS 12Gbps, MLC, hot plug, DWPD: 3

6.4TB Solid State Drive (512n / 12Gbps / 3DWPD)
MC-5DKG21 / MCX5DKG21 (LD)
 - SAS 12Gbps, MLC, hot plug, DWPD: 3

As flash memory cells are wearing parts, an SSD can only tolerate a limited number of write jobs. DWPD (Drive Write Per Day) is an indicator which specifies write endurance of an SSD. Depending on how the product is used, the number of writing times may reach the end of write endurance within the product lifespan. Product status can be confirmed by management tools such as iRMC Web-UI and Server View RAID Manager (SVRM).

→ Power Supply Unit (PSU)

9. Power Supply Unit (PSU)

July 2019 Ver. 2.0

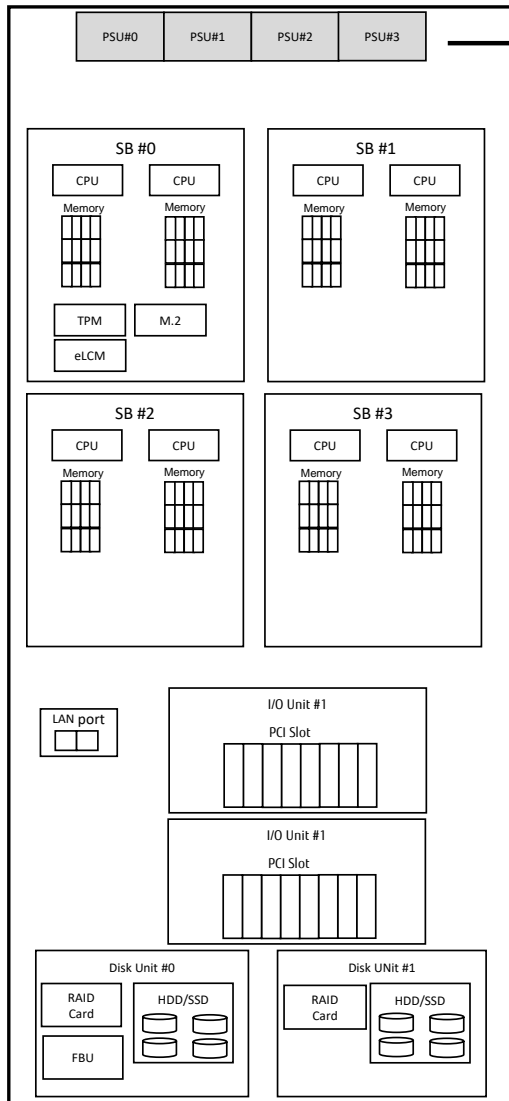

Power Supply Unit (PSU)

At least two PSUs need to be mounted per system.
Max. 4x PSUs can be mounted for PSU redundancy.

200V Normal PSU
MC-5HPS71 / MCX5HPS71 (LD)
- Max. 4x PSUs can be mounted for PSU redundancy.
- 80PLUS® Platinum certified

AC Power input	Redundancy	# of PSU	PSU Slots	Dual Power feed
240V	Not redundant	2	No restriction	No
	redundant	2+1	No restriction	
	redundant	3+1	No restriction	
	redundant	2+2	No restriction	Yes

Dual power feed configuration will help to supply power even in the event of data center power feed failure and PSU failure.

→ Power Cords for Base Unit

9.Power Cords for Base Unit for APAC and Americas

July 2019 Ver. 2.0

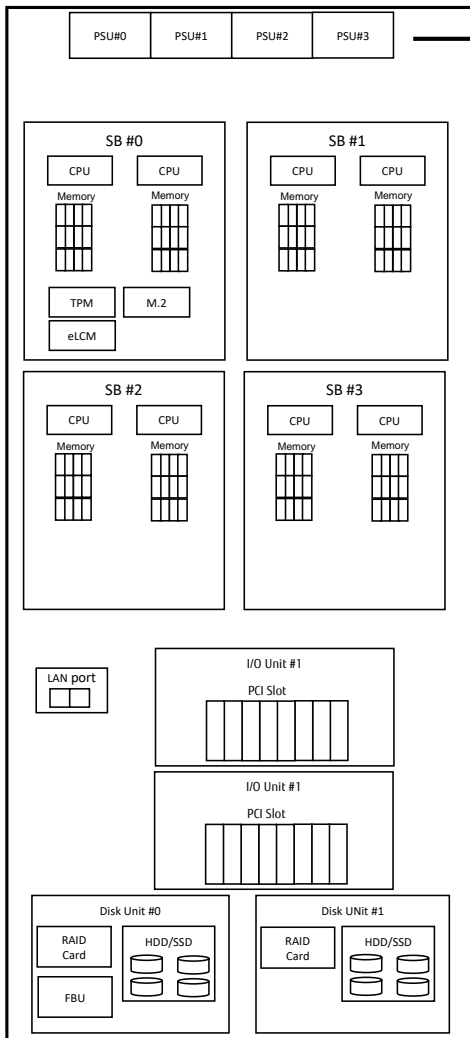

power cord

* The same quantity of Power Cords need to be ordered as that of PSU.

IEC AC(100V/200V) Cable (1m)
MC-0HCB11 / MCX0HCB11 (LD)
 - IEC60320 C20, 1m
 - power cord x 1

IEC AC(100V/200V) Cable (3m)
MC-0HCB13 / MCX0HCB13 (LD)
 - IEC60320 C20, 3m
 - power cord x 1

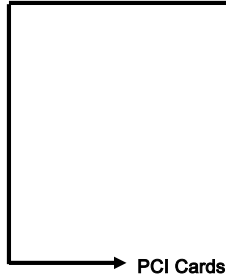

9.Power Cords for Base Unit for EMEA & India

July 2019 Ver. 2.0

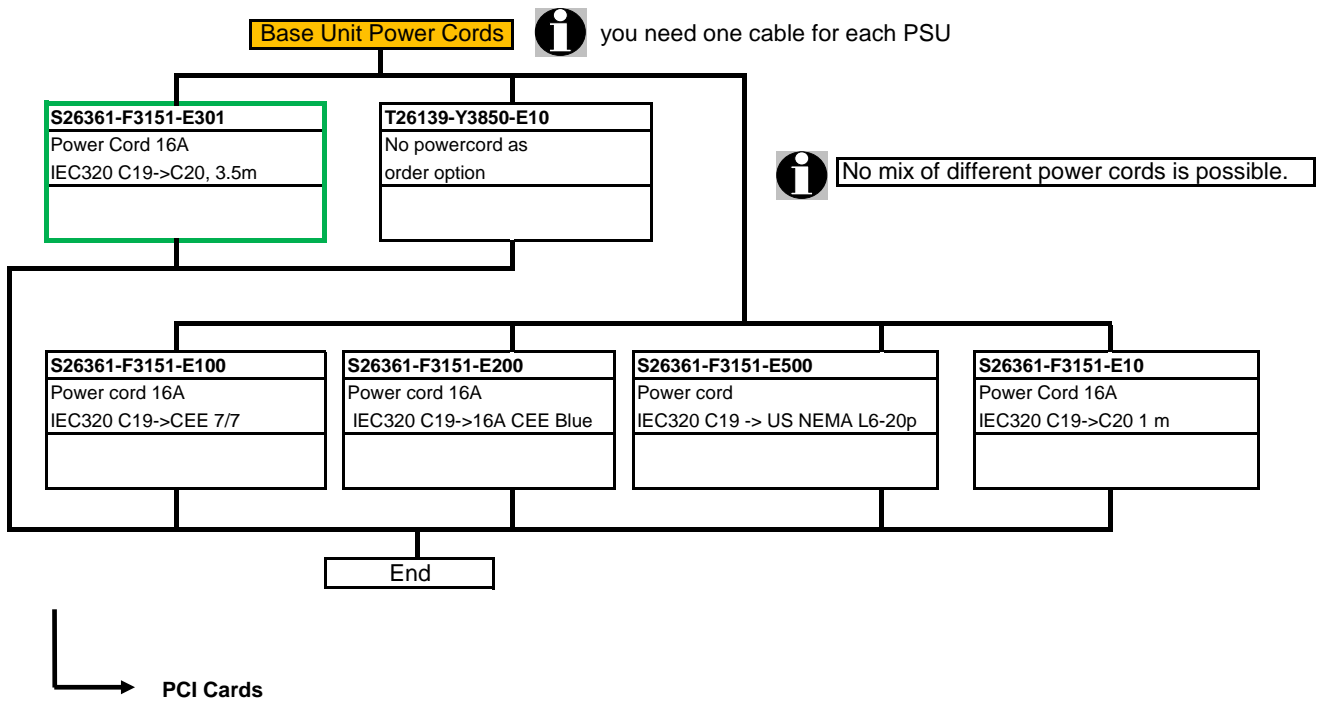

10. PCI Cards

July 2019 Ver. 2.0

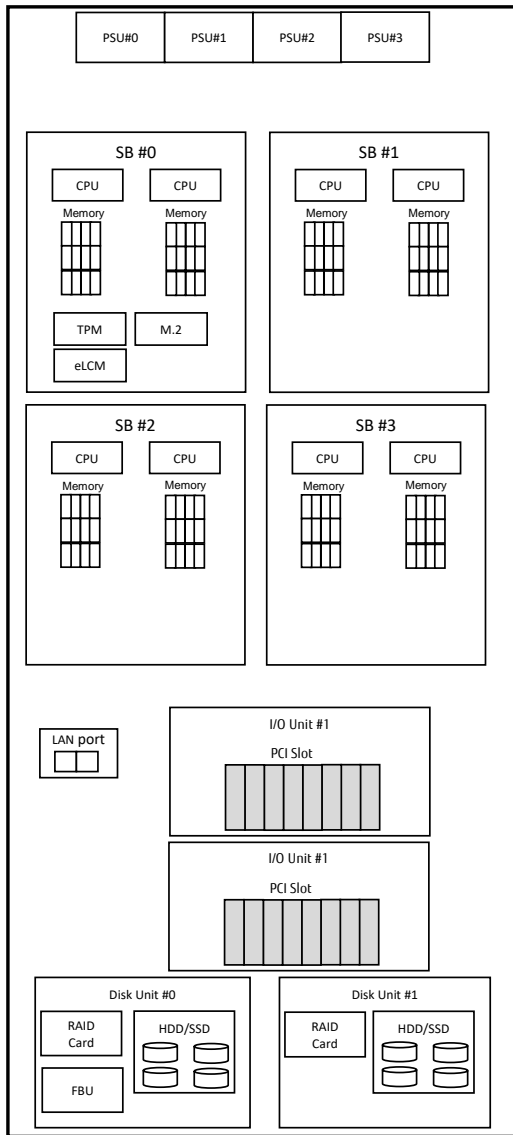

Max. 16 cards can be mounted in Base Unit.
 I/O Unit B : Max. 8 cards can be mounted per I/O Unit

- 2x PCIe Gen3 16Lane
- 2x PCIe Gen3 16Lane (hot pluggable slots)
- 4x PCIe Gen3 8Lane

PFC EP LPe31000 1x 16Gb Emulex LP
MC-0JFCF1 / MCX0JFCF1 (LD)
 - Single Channel 16Gbps Fibre Channel Card, Low Profile

PFC EP LPe31002 2x 16Gb Emulex LP
MC-0JFCG1 / MCX0JFCG1 (LD)
 - Dual Channel 16Gbps Fibre Channel Card, Low Profile

PFC EP LPe32000 1x 32Gb Broadcom LP
MC-0JFCM1 / MCX0JFCM1 (LD)
 - Single Channel 32Gbps Fibre Channel Card, Low Profile

PFC EP LPe32002 2x 32Gb Broadcom LP
MC-0JFCN1 / MCX0JFCN1 (LD)
 - Dual Channel 32Gbps Fibre Channel Card, Low Profile

PFC EP QLE2690 1x 16Gb Qlogic LP
MC-0JFCP1 / MCX0JFCP1 (LD)
 - Single Channel 16Gbps Fibre Channel Card, Low Profile

PFC EP QLE2692 2x 16Gb Qlogic LP
MC-0JFCQ1 / MCX0JFCQ1 (LD)
 - Dual Channel 16Gbps Fibre Channel Card, Low Profile

PFC EP QLE2740 1x 32Gb Cavium LP
MC-0JFCK1 / MCX0JFCK1 (LD)
 - Single Channel 32Gbps Fibre Channel Card, Low Profile

PFC EP QLE2742 2x 32Gb Cavium LP
MC-0JFCL1 / MCX0JFCL1 (LD)
 - Dual Channel 32Gbps Fibre Channel Card, Low Profile

→ PCI Cards 2

PCI Cards 2

July 2019 Ver. 2.0

Max. 16 cards can be mounted in Base Unit.
 I/O Unit B : Max. 8 cards can be mounted per I/O Unit

- 2x PCIe Gen3 16Lane
- 2x PCIe Gen3 16Lane (hot pluggable slots)
- 4x PCIe Gen3 8Lane

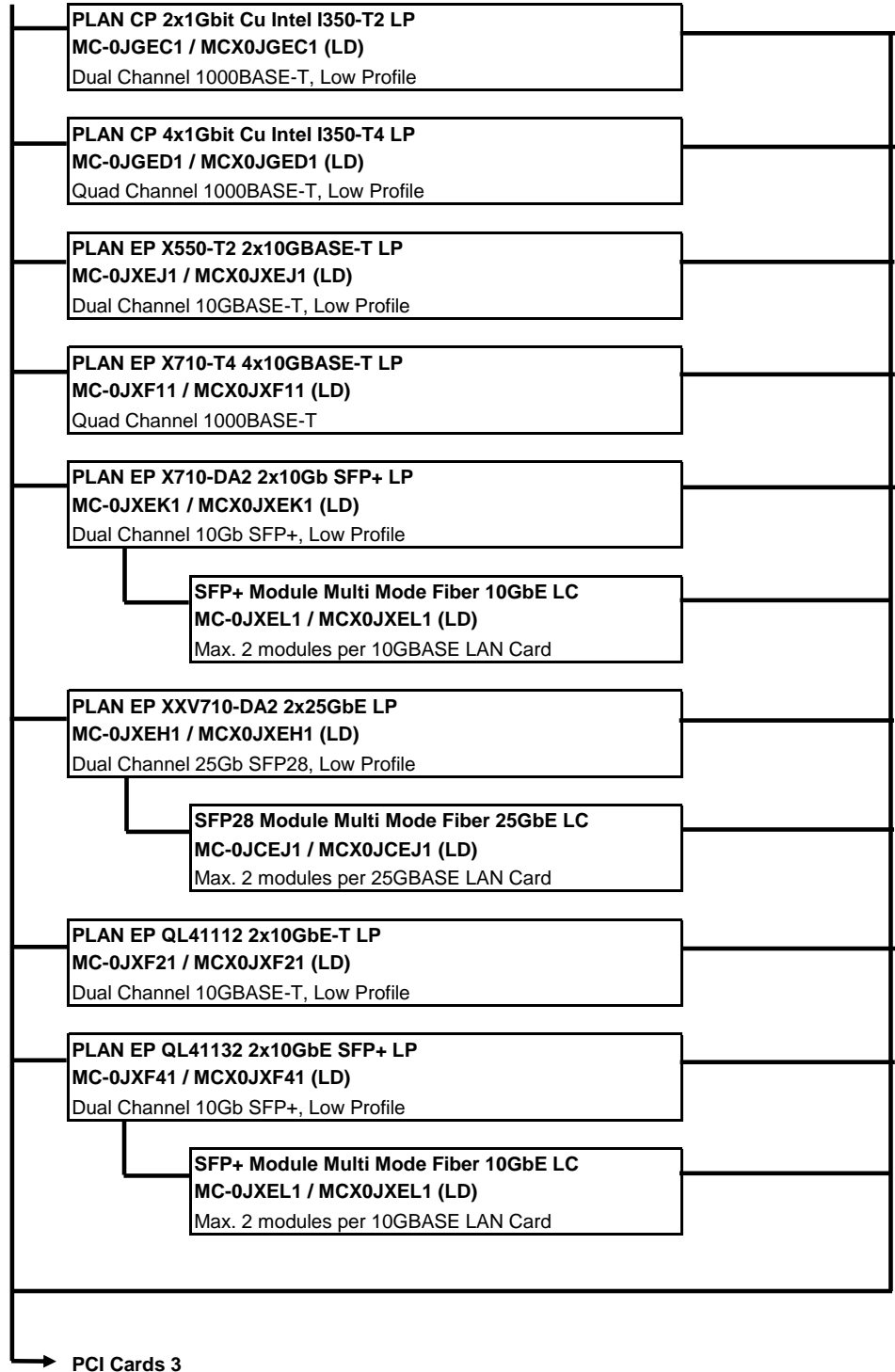

PCI Cards 3

July 2019 Ver. 2.0

Max. 16 cards can be mounted in Base Unit.
 I/O Unit B : Max. 8 cards can be mounted per I/O Unit
 - 2x PCIe Gen3 16Lane
 - 2x PCIe Gen3 16Lane (hot pluggable slots)
 - 4x PCIe Gen3 8Lane

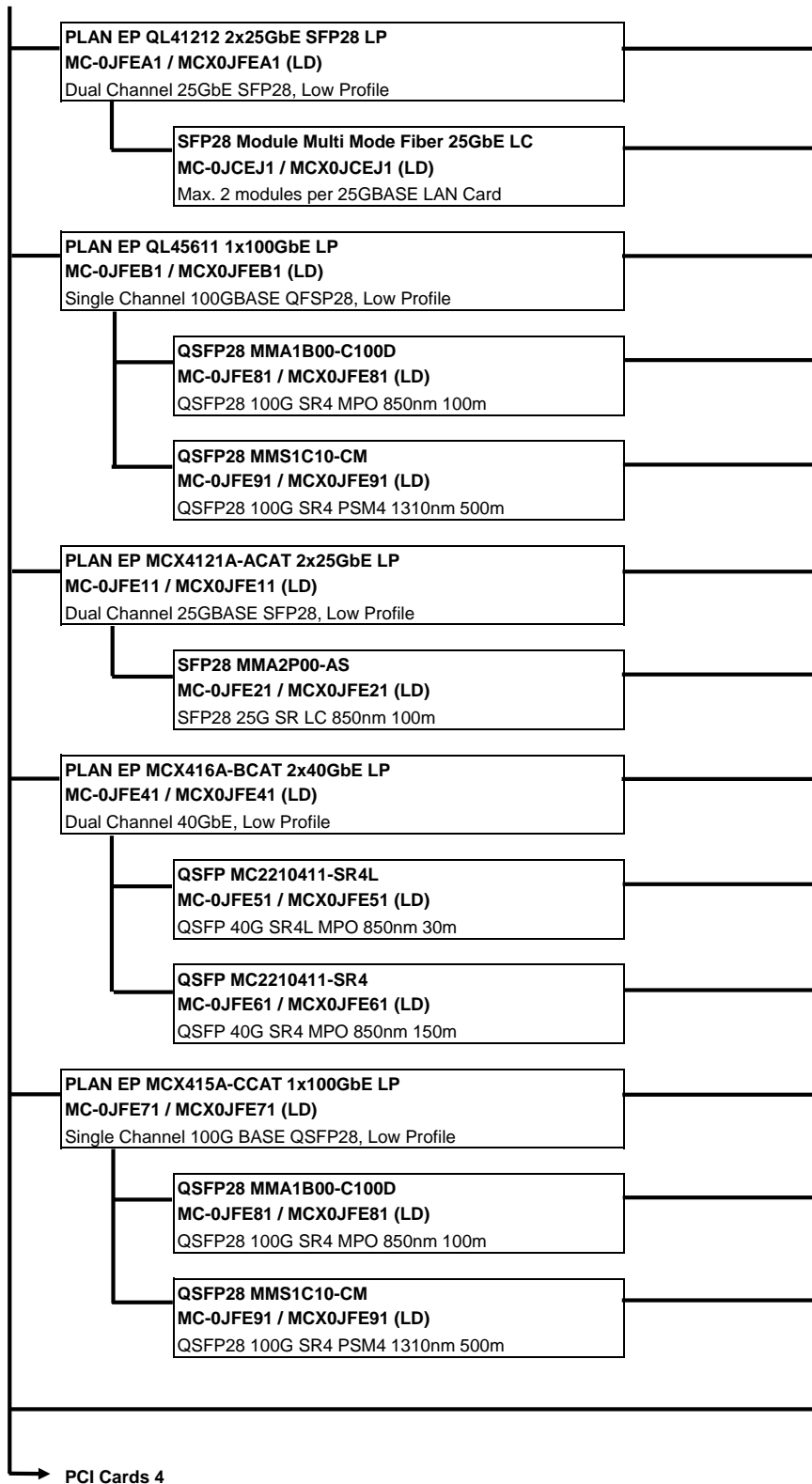

PCI Cards 4

July 2019 Ver. 2.0

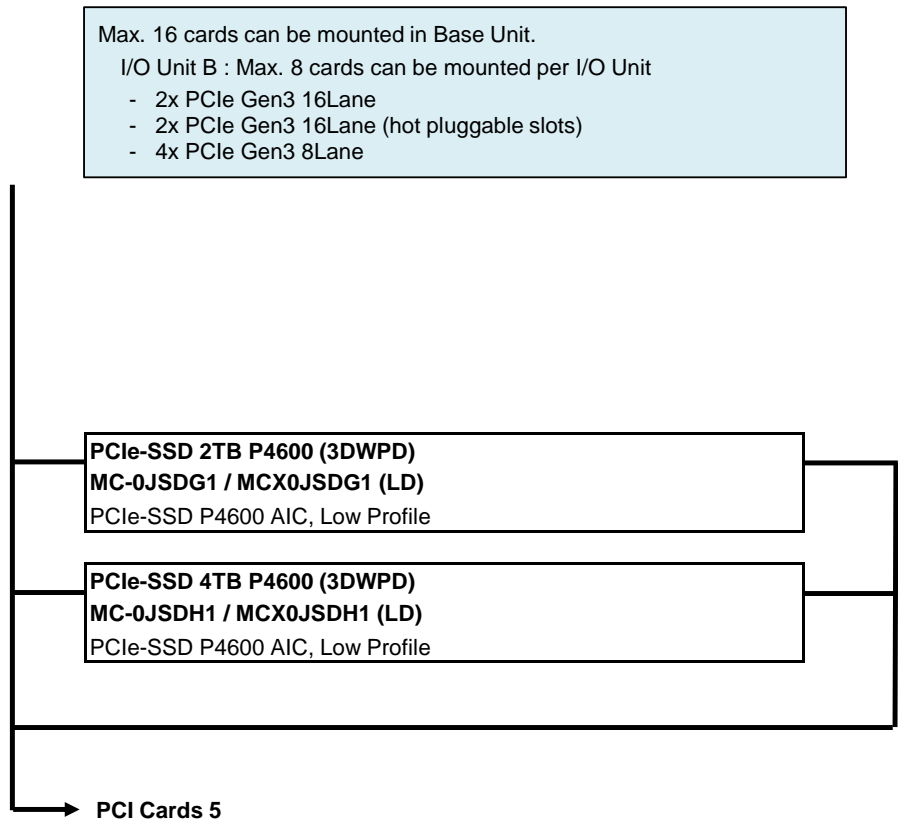

PCI Cards 5

July 2019 Ver. 2.0

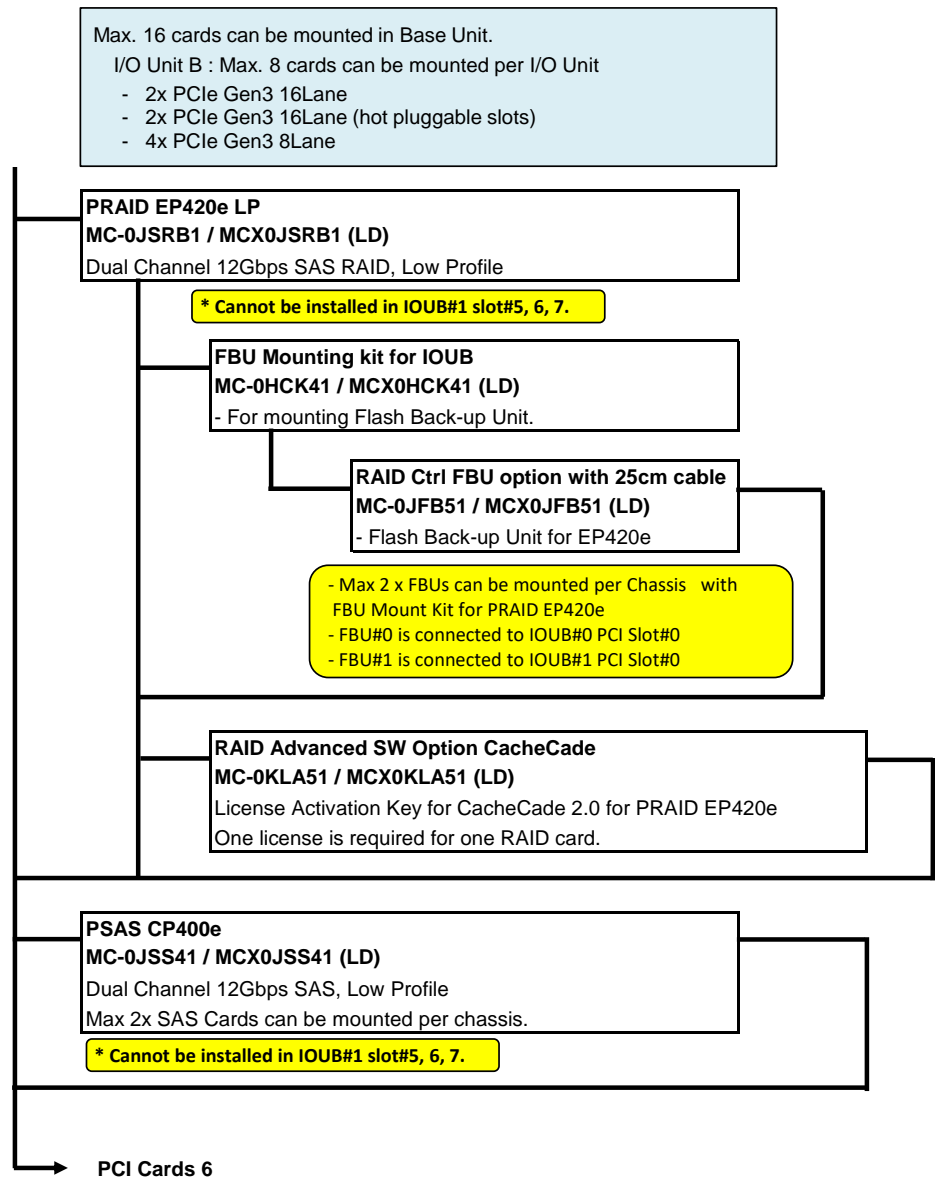

PCI Cards 6

July 2019 Ver. 2.0

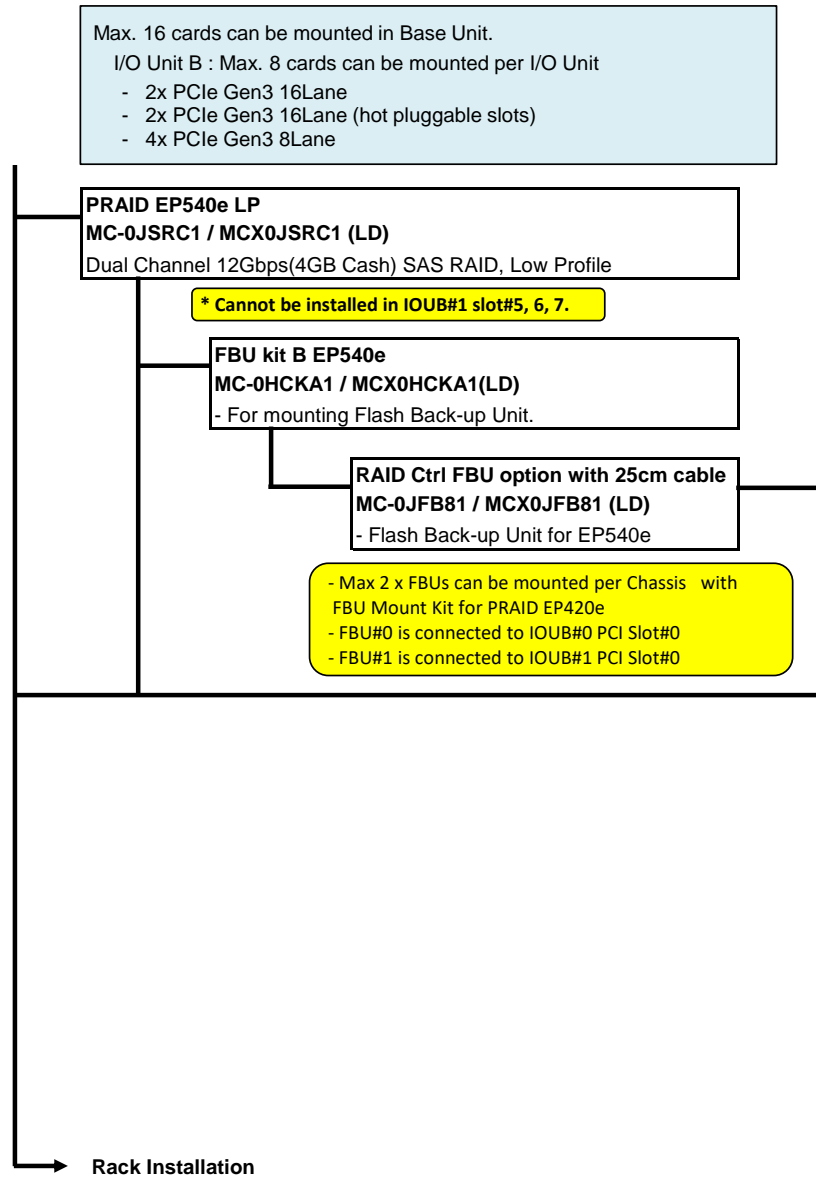

11. Rack Installation for APAC and Americas

July 2019 Ver. 2.0

For the details of rack products, please refer to "19 inch Rack Handbook".

<https://globalpartners.ts.fujitsu.com/sites/primeweb/services/servers/primequest/document/Pages/dc-h-guide.aspx>

Rack for APAC & Americas		Rack Mount Kit:
Rack Units Model 2724 Base Rack 19R-272A2 24U (Width 700mm x Depth 1,050mm x Height 1,200mm) Model 2737 Base Rack 19R-273A2 37U (Width 700mm x Depth 1,050mm x Height 1,792mm) Expansion Rack 19R-273B2 Model 2742 Base Rack 19R-274A2 42U (Width 700mm x Depth 1,050mm x Height 2,000mm) Expansion Rack 19R-274B2 Model 2616 Base Rack 19R-261A2 16U (Width 600mm x Depth 1,050mm x Height 845mm) Model 2624 Base Rack 19R-262A2 24U (Width 600mm x Depth 1,050mm x Height 1,200mm) Model 2642 Base Rack 19R-264A2 42U (Width 600mm x Depth 1,050mm x Height 2,000mm) Expansion Rack 19R-264B2		<ul style="list-style-type: none"> - can be used to mount PRIMEQUEST to Rack Units which are delivered from Fujitsu factories (Japan and Germany). - is bundled with PRIMEQUEST Base Unit.
Tilt-Resistant Stabilizer L-form Stabilizer 19R-27FS1 For Model 2724/2737/2742 L-form Stabilizer 19R-26FS1 For Model 2616/2624/2642 Pull out type Stabilizer 19R-26FS2 For Model 2724/2737/2742/2616/2624/2642		Tilt-Resistant Stabilizer: <ul style="list-style-type: none"> - If racks are not fixed to the floor, stabilizers should be ordered and jointed to the racks. - is NOT bundled with rack. Needs to be purchased.
Earthquake-Proof Kit Earthquake-proof Kit 19R-27ST1 For Base Rack for Model 2724/2737/2742 For front side, rear side, left side, and right side Earthquake-proof Kit 19R-27ST2 For Expansion Rack for Model 2724/2737/2742 For front side and rear side Earthquake-proof Kit 19R-26ST1 For Base Rack for Model 2616/2624/2642 For front side, rear side, left side, and right side Earthquake-proof Kit 19R-26ST2 For Expansion Rack for Model 2616/2624/2642 For front side and rear side		Earthquake-Proof Kit: <ul style="list-style-type: none"> - can fix racks to floor by anchoring racks to floor and using the kit holes. - To fix Earthquake-Proof Kit, please consult constructors.
Blank Panel Blank Panel (1U) 19R-26BP1 Blank Panel (2U) 19R-26BP2 Blank Panel (3U) 19R-26BP3		Blank Panel: <ul style="list-style-type: none"> - is used to prevent outflow of heated air into a vacant space. - space to joint Side Cable Duct, if they are not jointed, should be covered with Blank Panels. For Model 2724: 2 spaces (1U) For Model 2737/2742: 4 spaces (1U) - is NOT bundled with racks. Needs to be purchased.
Side Cable Duct Side Cable Duct 19R-27SD1 For Model 2724/2737/2742		Side Cable Duct: <ul style="list-style-type: none"> - is used to draw cables connected from the front side of equipments to the rear side of rack without occupying rack space by jointing the Side Cable Ducts to the apertures in the sides of racks. Model 2724: one aperture on each of left and right sides Model 2737/2742: 2 apertures on each of left and right sides - can accommodate around 90 cables with 5mm diameter. - If one aperture is not jointed with Side Cable Duct, the aperture should be covered with one 1U Blank Panel (19R-26BP1), which needs to be purchased.
Rack Tray Rack Tray (Fixed Type) 19R-26TR1 Rack Tray (Slide Type) 19R-26TR2 Laptop PC Tray 19R-26TR3		
Cable Holder Cable Holder for front side 19R-27CM1 * For Model 2724/2737/2742 Cable Holder for rear side 19R-27CM2 * For Model 2724/2737/2742 Cable Holder for front side 19R-26CM1 * For Model 2616/2624 Cable Holder for rear side 19R-26CM2 * For Model 2616/2624 Cable Holder for front side 19R-26CM11 * For Model 2642 Cable Holder for rear side 19R-26CM21 * For Model 2642		* Cable holders bundled to each rack: Model 2724: 6 pcs per Rack Model 2737: 8 pcs per Rack Model 2742: 10 pcs per Rack Model 2616: 4 pcs per Rack Model 2624: 6 pcs per Rack Model 2642: 10 pcs per Rack If the bundled quantity is insufficient, please purchase additional cable holders.
Screw kit Screw kit 19R-26SC1 50 pcs of M6 screws and 50 pcs of M6 cage nuts		Screw Kit: <ul style="list-style-type: none"> - Needs to be purchased if equipments do not include screws or nuts to be fixed in a rack. - is NOT bundled with the 19 inch racks.

End

Rack Installation for EMEA and India

July 2019 Ver. 2.0

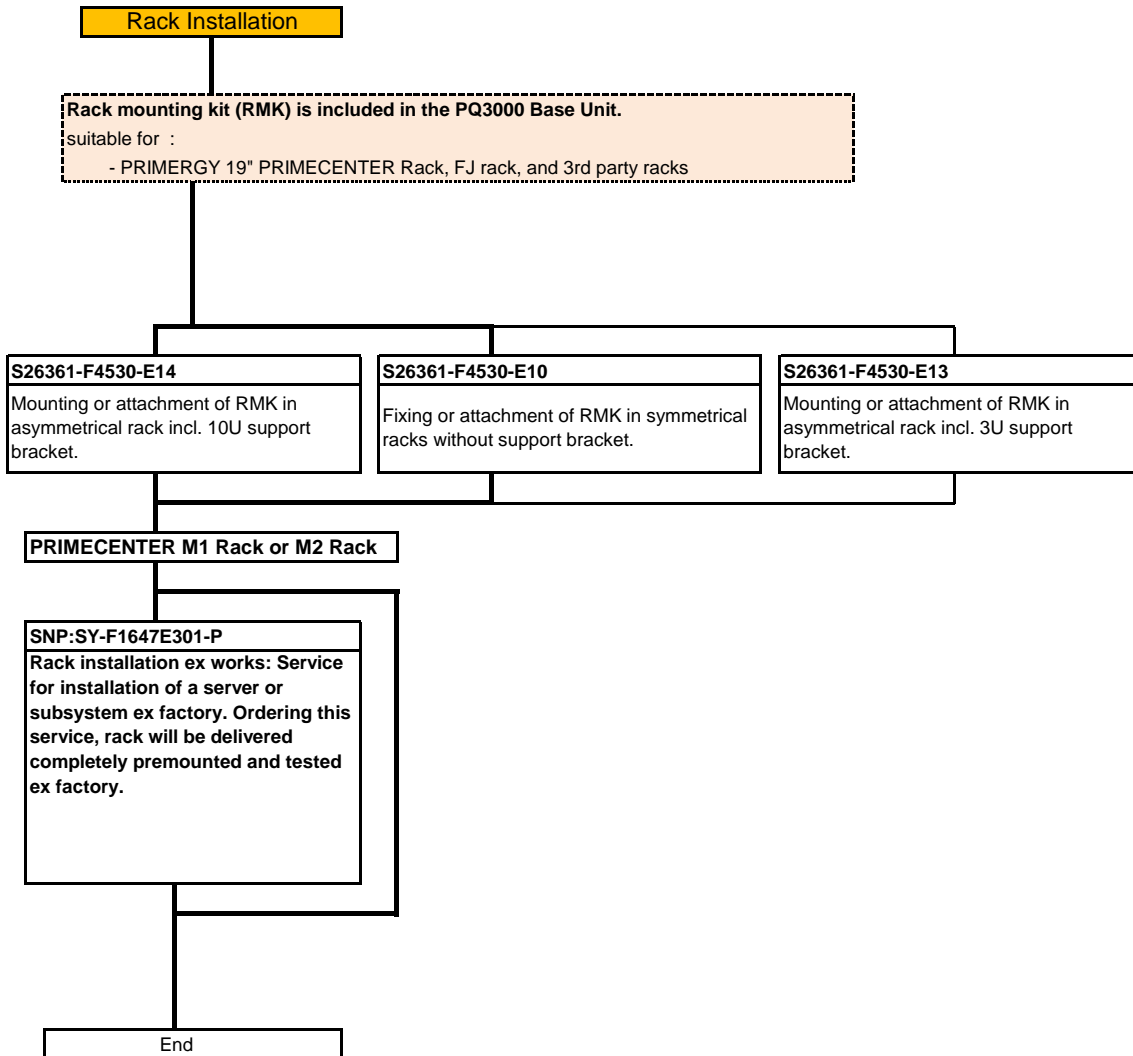

For more configuration information, RACK COMPONENTS, PDU & KVM please see:
<http://globalsp.ts.fujitsu.com/dmsp/Publications/public/cnfgPCM1rack.pdf>

12. Maximum Quantity of PCIe Cards

July 2019 Ver. 2.0

Maximum Quantity of PCIe Cards that can be mounted per Base Unit

Product Name			Order Number		Max. Qty		PHP
			Build-to-Order	Loose Delivery	3800B2	ESXi *5	
SAS RAID controller card (EP420i)	PRAID EP420i	*5 *8	MC-0JSRA1	MCX0JSRA1	2	total 2	No
SAS RAID controller card (EP540i)	PRAID EP540i	*5 *8	MC-0JSR71	MCX0JSR71	2		No
RAID controller card (EP580i)	PRAID EP580i	*5 *8	MC-0JSR81	MCX0JSR81	2		No
PRAID EP420e	PRAID EP420e	*4 *5 *7	MC-0JSRB1	MCX0JSRB1	2		No
PRAID EP540e	PRAID EP540e	*4 *5 *7	MC-0JSRC1	MCX0JSRC1	2		No
PSAS CP400e	PSAS CP400e	*7	MC-0JSS41	MCX0JSS41	2	2	No
PFC EP LPe31000 1x 16Gb Emulex	Broadcom LPe31000	*1 *2 *5	MC-0JFCF1	MCX0JFCF1	16 ports	total 8	Yes
PFC EP LPe31002 2x 16Gb Emulex	Broadcom LPe31002	*1 *2 *5	MC-0JFCG1	MCX0JFCG1			Yes
PFC EP LPe32000 1x 32Gb Broadcom	Broadcom LPe32000	*1 *2 *5	MC-0JFCM1	MCX0JFCM1	8 ports		Yes
PFC EP LPe32002 2x 32Gb Broadcom	Broadcom LPe32002	*1 *2 *5	MC-0JFCN1	MCX0JFCN1			Yes
PFC EP QLE2690 1x 16Gb Qlogic	Qlogic QLE2690	*1 *3 *5	MC-0JFCP1	MCX0JFCP1	16 ports		total 8
PFC EP QLE2692 2x 16Gb Qlogic	Qlogic QLE2692	*1 *3 *5	MC-0JFCQ1	MCX0JFCQ1		Yes	
PFC EP QLE2740 1x 32Gb Cavium	Qlogic QLE2740	*1 *3 *5	MC-0JFCK1	MCX0JFCK1	8 ports	Yes	
PFC EP QLE2742 2x 32Gb Cavium	Qlogic QLE2742	*1 *3 *5	MC-0JFCL1	MCX0JFCL1		Yes	
PLAN CP 2x1Gbit Cu Intel I350-T2	Intel I350-T2	*5	MC-0JGEC1	MCX0JGEC1	16	8	
PLAN CP 4x1Gbit Cu Intel I350-T4	Intel I350-T4	*5	MC-0JGED1	MCX0JGED1		4	Yes
PLAN EP X550-T2 2x10GBASE-T	Intel X550-T2	*5	MC-0JXEJ1	MCX0JXEJ1	16	8	Yes
PLAN EP X710-DA2 2x10Gb SFP+	Intel X710-DA2	*5	MC-0JXEK1	MCX0JXEK1		4	Yes
PLAN EP X710-T4 2x10GbE-T	Intel X710-T4	*5	MC-0JXF11	MCX0JXF11	8	4	Yes
PLAN EP XXV710-DA2 2x 25GbE	Intel XXV710-DA2	*5	MC-0JXEH1	MCX0JXEH1	4	2	Yes
PLAN EP QL41112 2x10GbE-T	Qlogic QL41112		MC-0JXF21	MCX0JXF21	16	8	Yes
PLAN EP QL41132 2x10GbE SFP+	Qlogic QL41132		MC-0JXF41	MCX0JXF41		4	Yes
PLAN EP QL41212 2x25GbE SFP28	Qlogic QL41212		MC-0JXFA1	MCX0JXFA1	4	4	Yes
PLAN EP QL45611 1x100GbE	Qlogic QL45611		MC-0JXFB1	MCX0JXFB1	2	2	Yes
PLAN EP MCX4121A-ACAT 2x25GbE	Mellanox MCX4121A-ACAT	*6 *5	MC-0JFE11	MCX0JFE11	4	total 4	Yes
PLAN EP MCX416A-BCAT 2x40GbE	Mellanox MCX416A-BCAT	*6 *5	MC-0JFE41	MCX0JFE41	2		Yes
PLAN EP MCX415A-CCAT 1x100GbE	Mellanox MCX415A-CCAT	*6 *5	MC-0JFE71	MCX0JFE71	2		Yes

Notes:

- *1) Broadcom Fibre Channel Cards and Qlogic Fibre Channel Cards CANNOT be used in the same chassis.
- *2) Max total quantity of "Broadcom Fibre Channel Cards" and "Broadcom LAN Cards" that can be mounted:
-16 x ports per chassis
- *3) Max total quantity of "Qlogic Fibre Channel Cards" that can be mounted:
-8 x cards per chassis
- *4) *PRAID EP420e/EP540e" with FBU can only be mounted IOU#0 PCI Slot#0 and IOU#1 PCI Slot#0
-2 x cards per chassis
- *5) EP420i and EP420e, or EP540i/580i and EP420e/EP540e are supported with a total of up to 2 cards by ESXi.
Emulex FC (LPe3100x, LPe3200x) is supported with a total of up to 8 cards by ESXi.
XXV710 is supported with a total of up to 2 cards by ESXi.
Qlogic FC (QLE2690, QLE2692, QLE2740, QLE2742) is supported with a total of up to 8 cards by ESXi.
Mellanox PLANs(25/40/100Gb) are supported with a total of up to 4 ports by ESXi.
Up to 16 10Gb ports are supported by ESXi 6.7.
Refer to the following documents for restriction on VMware vSphere.
<https://configmax.vmware.com/home>
- *6) Mixing of Mellanox 25G/40G/100G LAN card and 100G Infiniband HCA card is not allowed.
- *7) EP420e and CP400e are not allowed to be mounted on slot #5, #6, and #7 of the IOUB#1
- *8) EP420i and EP540i/580i are not allowed to be populated together.

13. Available OS

July 2019 Ver. 2.0

Product name	Order number		OS							
	Build to Order	Loose Delivery	Windows (1)	Windows (2)	Red Hat (3)	SUSE (4)	VMware (5)	Oracle Linux (6)	Oracle VM (7)	
PRIMEQUEST 3800B2 Base Unit	MCK3AC111B	NA	A	A	A	A	A	NA	NA	
Advanced Thermal Design Option	MC-0PTH2		-	-	-	-	-	-	-	
System Board	MC-3HSBD1B	MCX3HSBD1B	A	A	A	A	A	NA	NA	
eLKM Activation License (no load)	MC-6KMA11	MCX6KMA11	A	A	A	A	A	NA	NA	
TPM Module(v2.0)	MC-6HTP31	MCX6HTP31	NA	NA	A	A	A	NA	NA	
USB Flash Device 64GB Dual	MC-5FA411	MCX5FA411	NA	NA	NA	NA	A	NA	NA	
M.2 Flash Device (VMware, 240GB)	MC-5FB741	MCX5FB741	NA	NA	NA	NA	6.7U2	NA	NA	
M.2 Flash Device 240GB (except ESXI)	MC-5FB751	MCX5FB751	A	A	7.6	12SP4	NA	NA	NA	
M.2 Flash Device 480GB (except ESXI)	MC-5FB771	MCX5FB771	A	A	7.6	12SP4	6.7U2	NA	NA	
Intel Xeon Platinum 8280L Processor (28C/2.7GHz/4.5TB/205W)	MC-3BJA41B	MCX3BJA41B	A	A	A	A	A	NA	NA	
Intel Xeon Platinum 8280M Processor (28C/2.7GHz/2TB/205W)	MC-3BJA21B	MCX3BJA21B	A	A	A	A	A	NA	NA	
Intel Xeon Platinum 8280 Processor (28C/2.7GHz/1TB/205W)	MC-3BJA11B	MCX3BJA11B	A	A	A	A	A	NA	NA	
Intel Xeon Platinum 8276L Processor (28C/2.2GHz/4.5TB/165W)	MC-3BKA41B	MCX3BKA41B	A	A	A	A	A	NA	NA	
Intel Xeon Platinum 8276M Processor (28C/2.2GHz/2TB/165W)	MC-3BKA21B	MCX3BKA21B	A	A	A	A	A	NA	NA	
Intel Xeon Platinum 8276 Processor (28C/2.2GHz/1TB/165W)	MC-3BKA11B	MCX3BKA11B	A	A	A	A	A	NA	NA	
Intel Xeon Platinum 8270 Processor (26C/2.7GHz/1TB/205W)	MC-3BKB11B	MCX3BKB11B	A	A	A	A	A	NA	NA	
Intel Xeon Platinum 8268 Processor (24C/2.9GHz/1TB/205W)	MC-3BJC11B	MCX3BJC11B	A	A	A	A	A	NA	NA	
Intel Xeon Platinum 8260L Processor (24C/2.4GHz/4.5TB/165W)	MC-3BKC41B	MCX3BKC41B	A	A	A	A	A	NA	NA	
Intel Xeon Platinum 8260M Processor (24C/2.4GHz/2TB/165W)	MC-3BKC21B	MCX3BKC21B	A	A	A	A	A	NA	NA	
Intel Xeon Platinum 8260 Processor (24C/2.4GHz/1TB/165W)	MC-3BKC11B	MCX3BKC11B	A	A	A	A	A	NA	NA	
Intel Xeon Platinum 8256 Processor (4C/3.8GHz/1TB/105W)	MC-3BKN11B	MCX3BKN11B	A	A	A	A	A	NA	NA	
Intel Xeon Platinum 8253 Processor (16C/2.2GHz/1TB/125W)	MC-3BKG11B	MCX3BKG11B	A	A	A	A	A	NA	NA	
32GB Memory (16GB 1Rx4 DDR4 RDIMM x2)	MC-3CE611B	MCX3CE611B	A	A	A	A	A	NA	NA	
64GB Memory (32GB 2Rx4 DDR4 RDIMM x2)	MC-3CE711B	MCX3CE711B	A	A	A	A	A	NA	NA	
128GB Memory (64GB 2Rx4 DDR4 RDIMM x2)	MC-3CE811B	MCX3CE811B	A	A	A	A	A	NA	NA	
128GB Memory (64GB 4Rx4 DDR4 LRDIMM x2)	MC-3CE821B	MCX3CE821B	A	A	A	A	A	NA	NA	
256GB Memory (128GB 8Rx4 DDR4 RDIMM 3DS x2)	MC-3CE911B	MCX3CE911B	A	A	A	A	A	NA	NA	
512GB Memory (256GB 8Rx4 DDR4 LRDIMM 3DS x2)	MC-3CEA11B	MCX3CEA11B	A	A	A	A	A	NA	NA	
128GB DDR-T DCPMM (NVM/LRDIMM)	<i>*Special Release</i>		A	A	A	A	A	NA	NA	
256GB DDR-T DCPMM (NVM/LRDIMM)	<i>*Special Release</i>		A	A	A	A	A	NA	NA	
512GB DDR-T DCPMM (NVM/LRDIMM)	<i>*Special Release</i>		A	A	A	A	A	NA	NA	
Memory Mode Performance Installation	MC-0PMM5		-	-	-	-	-	-	-	
Memory Mode Mirror Installation	MC-0PMM7		-	-	-	-	-	-	-	
Memory Mode Normal or Spare Installation	MC-0PMM8		-	-	-	-	-	-	-	
I/O Unit B	MC-3HUX61B	MCX3HUX61B	A	A	A	A	A	NA	NA	
Disk Unit for SAS (DU_SAS)	MC-5HDX31B	MCX5HDX31B	A	A	A	A	A	NA	NA	
SAS RAID controller card (EP420i)	MC-0JSRA1	MCX0JSRA1	A	A	A	A	A	NA	NA	
SAS RAID controller card (EP540i)	MC-0JSR71	MCX0JSR71	A	A	A	A	A	NA	NA	
SAS RAID controller card (EP580i)	MC-0JSR81	MCX0JSR81	A	A	A	A	A	NA	NA	
RAID controller card (EP540e)	MC-0JSRC1	MCX0JSRC1	A	A	p	15	6.7U2	NA	NA	
Flash Back-up Unit for EP420i	MC-0JFB61	MCX0JFB61	-	-	-	-	-	-	-	
Flash Back-up Unit for EP5x0i	MC-0JFB41	MCX0JFB41	-	-	-	-	-	-	-	
Flash Back-up Unit for EP540e	MC-0JFB81	MCX0JFB81	-	-	-	-	-	-	-	
RAID Advanced SW Option CacheCade	MC-0KLA51	MCX0KLA51	A	A	A	A	A	NA	NA	
300GB Hard Disk Drive (512n/12Gbps/15,000rpm)	MC-5DS771	MCX5DS771	A	A	A	A	A	NA	NA	
600GB Hard Disk Drive (512n/12Gbps/15,000rpm)	MC-5DS961	MCX5DS961	A	A	A	A	A	NA	NA	
900GB Hard Disk Drive (512n/12Gbps/15,000rpm)	MC-5DSA51	MCX5DSA51	A	A	A	A	A	NA	NA	
300GB Hard Disk Drive (512n/12Gbps/10,000rpm)	MC-5DS781	MCX5DS781	A	A	A	A	A	NA	NA	
600GB Hard Disk Drive (512n/12Gbps/10,000rpm)	MC-5DS971	MCX5DS971	A	A	A	A	A	NA	NA	
900GB Hard Disk Drive (512n/12Gbps/10,000rpm)	MC-5DSA61	MCX5DSA61	A	A	A	A	A	NA	NA	
1.2TB Hard Disk Drive (512n/12Gbps/10,000rpm)	MC-5DSB41	MCX5DSB41	A	A	A	A	A	NA	NA	
1.8TB Hard Disk Drive (512e/12Gbps/10,000rpm)	MC-5DSC21	MCX5DSC21	A	A	A	A	A	NA	NA	
2.4TB Hard Disk Drive (512e/12Gbps/10,000rpm)	MC-5DSD11	MCX5DSD11	A	A	A	A	A	NA	NA	
400GB Solid State Drive (512n/12Gbps/10DWPD)	MC-5DG821	MCX5DG821	A	A	A	A	A	NA	NA	
800GB Solid State Drive (512n/12Gbps/10DWPD)	MC-5DG921	MCX5DG921	A	A	A	A	A	NA	NA	
1.6TB Solid State Drive (512n/12Gbps/10DWPD)	MC-5DGA21	MCX5DGA21	A	A	A	A	A	NA	NA	
400GB Solid State Drive (512n/12Gbps/3WPD)	MC-5DH821	MCX5DH821	A	A	A	A	A	NA	NA	
800GB Solid State Drive (512n/12Gbps/3DWPD)	MC-5DH921	MCX5DH921	A	A	A	A	A	NA	NA	
1.6TB Solid State Drive (512n/12Gbps/3DWPD)	MC-5DHA21	MCX5DHA21	A	A	A	A	A	NA	NA	
3.2TB Solid State Drive (512n/12Gbps/3DWPD)	MC-5DHB21	MCX5DHB21	A	A	A	A	A	NA	NA	
6.4TB Solid State Drive (512n/12Gbps/3DWPD)	MC-5DKG21	MCX5DKG21	A	A	A	A	A	NA	NA	
100V/200V normal PSU	MC-5HPS71	MCX5HPS71	-	-	-	-	-	-	-	
IEC AC(100V/200V) Cable (1m)	MC-0HCB11	MCX0HCB11	-	-	-	-	-	-	-	
IEC AC(100V/200V) Cable (3m)	MC-0HCB13	MCX0HCB13	-	-	-	-	-	-	-	

- (1) Microsoft® Windows Server® 2016 (Standard/Datacenter)
- (2) Microsoft® Windows Server® 2019 (Standard / Datacenter)
- (3) Red Hat® Enterprise Linux® 7.6 / 8.0
- (4) SUSE® Linux Enterprise Server 12 SP4 / 15
- (5) VMware vSphere® 6.7 U1 / 6.7U2
- (6) Oracle® Linux 7
- (7) Oracle® VM 3.4

A : Available
 NA : Not Available
 p : planned

*EP420i
 *EP540i
 *EP580i
 *EP540e

13.Available OS

July 2019 Ver. 2.0

Product name	Order number		OS								
	Build to Order	Loose Delivery	Win2016 (1)	Win2019 (2)	Red Hat (3)	SLES (4)	VMware (5)	Oracle Linux (6)	Oracle VM (7)		
PFC EP LPe31000 1x 16Gb Emulex	MC-0JFCF1	MCX0JFCF1	A	p	A	A	A	NA	NA	(1) Microsoft® Windows Server® 2016 (Standard/Datacenter)	
PFC EP LPe31002 2x 16Gb Emulex	MC-0JFCG1	MCX0JFCG1	A	p	A	A	A	NA	NA	(2) Microsoft® Windows Server® 2019 (Standard / Datacenter)	
PFC EP LPe32000 1x 32Gb Broadcom	MC-0JFCM1	MCX0JFCM1	A	p	A	A	A	NA	NA	(3) Red Hat® Enterprise Linux® 7.6 / 8.0	
PFC EP LPe32002 2x 32Gb Broadcom	MC-0JFCN1	MCX0JFCN1	A	p	A	A	A	NA	NA	(4) SUSE® Linux Enterprise Server 12 SP4 / 15	
PFC EP QLE2690 1x 16Gb Qlogic	MC-0JFCP1	MCX0JFCP1	A	p	p	p	A	NA	NA	(5) VMware vSphere® 6.7 U1 / 6.7U2	
PFC EP QLE2692 2x 16Gb Qlogic	MC-0JFCQ1	MCX0JFCQ1	A	p	p	p	A	NA	NA	(6) Oracle® Linux 7	
PFC EP QLE2740 1x 32Gb Qlogic	MC-0JFCK1	MCX0JFCK1	A	p	p	p	A	NA	NA	(7) Oracle® VM 3.4	
PFC EP QLE2742 2x 32Gb Qlogic	MC-0JFCL1	MCX0JFCL1	A	p	p	p	A	NA	NA	* Broadcom LPe31000	
PLAN CP 2x1Gbit Cu Intel I350-T2	MC-0JGEC1	MCX0JGEC1	A	p	A	A	A	NA	NA	* Broadcom LPe31002	
PLAN CP 4x1Gbit Cu Intel I350-T4	MC-0JGED1	MCX0JGED1	A	p	A	A	A	NA	NA	* Broadcom LPe32000	
PLAN EP X550-T2 2x10GBASE-T	MC-0JXEJ1	MCX0JXEJ1	A	p	A	p	A	NA	NA	* Broadcom LPe32002	
PLAN EP X710-T4 4x10GBASE-T LP	MC-0JXF11	MCX0JXF11	p	p	A	p	6.7U2	NA	NA	* Qlogic QLE2690	
PLAN EP X710-DA2 2x10Gb SFP+	MC-0JXEK1	MCX0JXEK1	A	p	A	p	A	NA	NA	* Qlogic QLE2692	
SFP+ Module Multi Mode Fiber 10GbE LC	MC-0JXEL1	MCX0JXEL1	-	-	-	-	-	-	-	* Qlogic QLE2740	
PLAN EP XXV710-DA2 2x 25GbE	MC-0JXEH1	MCX0JXEH1	A	p	A	p	A	NA	NA	* Qlogic QLE2742	
SFP28 Module Multi Mode Fiber 25GbE LC	MC-0JCEJ1	MCX0JCEJ1	-	-	-	-	-	-	-	* Intel I350-T2	
PLAN EP QL41112 2x10GbE-T	MC-0JXF21	MCX0JXF21	A	p	p	15	A	NA	NA	* Intel I350-T4	
PLAN EP QL41112 2x10GbE-T	MC-0JXF41	MCX0JXF41	A	p	p	15	A	NA	NA	* Intel X550-T2	
PLAN EP QL41212 2x25GbE SFP28	MC-0JFEA1	MCX0JFEA1	A	p	p	15	A	NA	NA	* Intel X710-T4	
PLAN EP QL45611 1x100GbE	MC-0JFEB1	MCX0JFEB1	A	p	p	15	A	NA	NA	* Intel X710-DA2	
QSFP28 MMA1B00-C100D	MC-0JFE81	MCX0JFE81	-	-	-	-	-	-	-	* Intel XXV710-DA2	
QSFP28 MMS1C10-CM	MC-0JFE91	MCX0JFE91	-	-	-	-	-	-	-	* Cavium QL41112HLRJ	
PLAN EP MCX4121A-ACAT 2x25GbE	MC-0JFE11	MCX0JFE11	A	A	7.6	15	6.7U2	NA	NA	* Cavium QL41132HLCU	
SFP28 MMA2P00-AS	MC-0JFE21	MCX0JFE21	-	-	-	-	-	-	-	* Cavium QL41212	
PLAN EP MCX416A-BCAT 2x40GbE	MC-0JFE41	MCX0JFE41	A	A	7.6	15	6.7U2	NA	NA	* Cavium QL45611HLCU	
QSFP MC2210411-SR4L	MC-0JFE51	MCX0JFE51	-	-	-	-	-	-	-	* QSFP28 100G SR4 MPO 850nm 100m	
QSFP MC2210411-SR4	MC-0JFE61	MCX0JFE61	-	-	-	-	-	-	-	* QSFP28 100G PSM4 1310nm 500m	
PLAN EP MCX415A-CCAT 1x100GbE	MC-0JFE71	MCX0JFE71	A	A	7.6	15	6.7U2	NA	NA	* Mellanox MCX4121A-ACAT	
PCIe-SSD 2TB P4600 (3DWPDP)	MC-0JSDG1	MCX0JSDG1	A	p	p	p	6.7U1	NA	NA	* SFP28 25G SR LC 850nm 100m	
PCIe-SSD 4TB P4600 (3DWPDP)	MC-0JSDH1	MCX0JSDH1	A	p	p	p	6.7U1	NA	NA	* Mellanox MCX416A-BCAT	
PRAID EP420e	MC-0JSRB1	MCX0JSRB1	A	A	A	A	A	NA	NA	* QSFP 40G SR4L MPO 850nm 30m	
RAID Ctrl FBU option with 25cm cable	MC-0JFB51	MCX0JFB51	-	-	-	-	-	-	-	* QSFP 40G SR4 MPO 850nm 150m	
FBU Mounting kit for IOUB	MC-0HCK41	MCX0HCK41	-	-	-	-	-	-	-	* Mellanox MCX415A-CCAT	
FBU kit B EP540e	MC-0HCKA1	MCX0HCKA1	-	-	-	-	-	-	-	* Intel P4600 SSD AIC	
PSAS CP400e	MC-0JSS41	MCX0JSS41	A	p	A	A	A	NA	NA	* Intel P4600 SSD AIC	

14.Restrictions

July 2019 Ver. 2.0

The followin functions are restricted as of April 2019.

No.	
1	Intel 10GbE LAN cards [MC*0JXEK*] (X710-DA2) cannot be mounted to PHP slots (#2 and #3 slots of IOU).
2	"Intel TXT" does not work.
3	Intel 10GbE-T LAN cards [MC*0JXEJ*] (X550-T2) does not work on Windows OS with Legacy mode.
4	Please update NVM version to 6.01 when XXV710-DA2 [MC*0JXEH1] and X710-DA2 [MC*0JXEK*] are mounted to the same chassis.
5	Mellanox 25/40/100Gb LAN cards [MC*0JFE11/MC*0JFE41/MC*0JFE71], Infiniband cards do not work in the same chassis.
6	Intel TXT function of Windows Server 2016 does not work with PRIMEQUEST.
7	In the Legacy mode, the installation of Windows OS cannot be done to the M.2 flash device [MC*5FB741/MC*5FB751]. Please use the uEFI mode.
8	Please install Windows Server 2019 with "Hyper Threading = OFF".
9	TPM module does not work with Windows Server 2019.
10	The iSCSI does not work with VMware 6.5.
11	Address range mirror is not supported with VMware.
12	Secure Boot does not work with Linux OSes.
13	M.2 Flash device with only SLES12 SP4 are supported. Other OSes are planned.
14	Oracle Linux/VM do not support SAN-Boot.

July 2019 Ver. 2.0

Change Report

Date	Order number	Changes
kwi. 02, 2019		Ver. 1.0
lip. 02, 2019		Ver. 2.0