

# Brocade VDX 6940 Switches

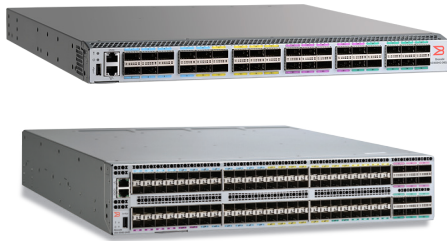

## HIGHLIGHTS

- Delivers zero-touch scale-out through auto-forming fabric based on Brocade VCS Fabric technology
- Offers the market's highest 10 GbE and 40 GbE density in a fixed form factor
- Delivers optimized packet buffer and latency for better application performance
- Seamlessly unifies physical and virtual resources with Brocade VCS Gateway for NSX
- Manages an entire multitenant Brocade VCS fabric as a single switch
- Enables IP storage networking for improved performance, management, security, and span of control
- Enables efficiently load-balanced multipathing at Layers 1, 2, and 3, as well as multiple Layer 3 gateways
- Provides the industry's most open programmability and Software-Defined Networking (SDN) choice with a plugin for OpenStack, support for REST APIs, and OpenFlow 1.3 and DevOps integration for Puppet and Python

## Scale Out the Data Center Like Never Before

The data center is evolving, driving requirements for infrastructure that can support dynamic growth in Virtual Machines (VMs), distributed applications, and Big Data, as well as the transition to cloud-based computing—without compromising performance. However, traditional data centers typically use inflexible, three-tier network designs that cannot efficiently manage east-west traffic or deliver the bandwidth needed to support virtualization and new service delivery. In addition, with the growth in cloud computing, a scalable, open, programmable, agile, and responsive network infrastructure is essential.

IT service delivery and data center operators need networks that are high performance, operationally efficient, automated, and elastic. The ideal network also must be easy to manage and scale out to meet demand as well as adapt to future requirements.

## Optimizing Scale-out Architecture

Brocade® VDX® switches are designed to help organizations stay ahead of application-driven network change by enabling agile growth through a scale-out architecture. This approach offers three key benefits. First, it enables network expansion as a business grows over time. One can horizontally scale spine switches as the number of leaf switches increase. Second, scale-out architecture also enables the creation of resilient network fabrics, eliminating a single point of failure and potential downtime. Third, and most important, a scale-out network architecture delivers a compelling economic benefit.

Unlike scale-up, a scale-out model lowers upfront investment. And by using high-density fixed switches, it lowers the Total Cost of Ownership (TCO), reducing power, cooling, and data center space.

Brocade VCS® Fabric technology was designed from the ground up to facilitate and optimize these scale-out architectures. With zero-touch capabilities, scale-out is simple. Organizations can add, move, or remove network resources without changing configurations to the existing network. Resiliency is baked into the VCS fabric at every layer. And by employing multipathing at Layers 1, 2, and 3, the VCS fabric eliminates any single point of failure.

**WHY CHOOSE BROCADE VCS FABRICS TO OPTIMIZE SCALE-OUT ARCHITECTURE**

- **Zero-touch scale-out:** VCS fabric automation (zero-touch provisioning, self-forming trunks, logical chassis) enables administrators to add, move, and delete capacity automatically.
- **Integrated resiliency:** Multipathing at Layers 1, 2, and 3 provides resiliency at every network layer.
- **Simplified operation:** VCS fabrics offer a single point of management.
- **Compelling economics:** Organizations can reduce OpEx by 50 percent and increase network utilization by 100 percent with Brocade VCS fabrics integrated with Brocade VDX switches.

**Classic Hierarchical Ethernet Architecture**

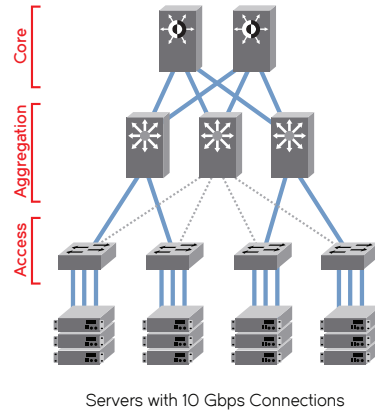

**Ethernet Fabric Architecture**

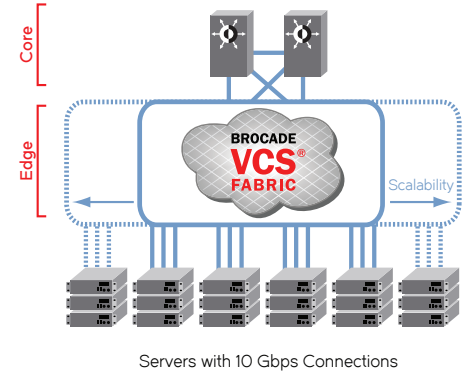
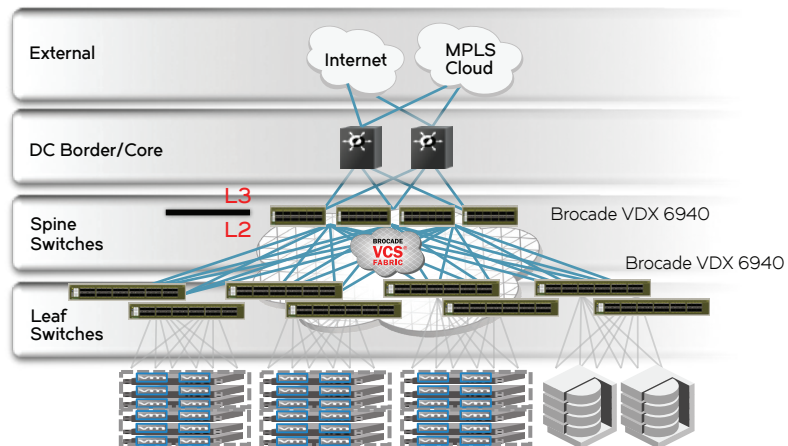

**Figure 1:** Compared to classic Ethernet architectures, Ethernet fabrics allow all paths to be active and provide greater scalability—while reducing management complexity.

**Brocade VDX 6940 Switches**

The Brocade VDX 6940-36Q is a fixed 40 Gigabit Ethernet (GbE) optimized switch in a 1U form factor. It offers 36 40 GbE QSFP+ ports and can be deployed as a spine or leaf switch. Each 40 GbE port can be broken out into four independent 10 GbE SFP+ ports, providing a total of 144 10 GbE SFP+. Deployed as a spine, it provides options to connect either 40 GbE or 10 GbE uplinks from leaf switches. By deploying this high-density, compact switch, administrators can reduce their TCO through savings on power, space, and cooling.

In a leaf deployment, 10 GbE and 40 GbE ports can be mixed, offering flexible design options to cost-effectively support demanding data center and service provider environments. As in other Brocade VDX platforms, the Brocade VDX 6940-36Q offers a Ports on Demand (PoD) licensing model. Brocade VDX 6940-36Q is available with 24 ports or 36 ports. The 24-port model offers a lower entry point for organizations that want to start small and grow their networks over time. By installing a software license, organizations can upgrade their 24-port switch to the maximum 36-port switch.



**Figure 2:** The Brocade VDX 6940-36Q Switch in spine and leaf architectures.

The Brocade VDX 6940-144S is a 10 GbE optimized switch with 40 GbE or 100 GbE uplinks in a 2U form factor. It offers 96 native 1/10 GbE SFP/SFP+ ports and 12 40 GbE QSFP+ ports, or 4 100 GbE QSFP28 ports. In addition, the Brocade VDX 6940-144S provides flexibility for uplinks, 40 GbE or 100 GbE from leaf switches, and delivers greater cross-sectional bandwidth for east-west traffic. Purpose-built for scale-out data centers and service providers, it enables aggregation of multiple server racks with a single switch.

With its high density, the Brocade VDX 6940-144S is an ideal fit for middle-of-row or end-of-row data center deployments. By connecting multiple racks to a single cut-through switch, this architecture offers greater cross-sectional bandwidth for applications. Servers from multiple racks can be just one hop away from one another. The compact 2U form factor saves space, also reducing power and cooling, resulting in lower TCO for organizations.

For both the Brocade VDX 6940-36Q and 6940-144S, front access ports are positioned to enable easy server or switch connectivity and to simplify cabling. With a choice of front-to-back or back-to-front airflow, these switches are ideal for deployments connecting servers, storage, and other switches, as well as for providing compatibility for either hot aisle or cold aisle data center designs. For the 40 GbE ports that also support 10 GbE connections with breakout cables, the switches offer the flexibility needed to support a mixed environment as data centers or service providers transition to higher bandwidth.

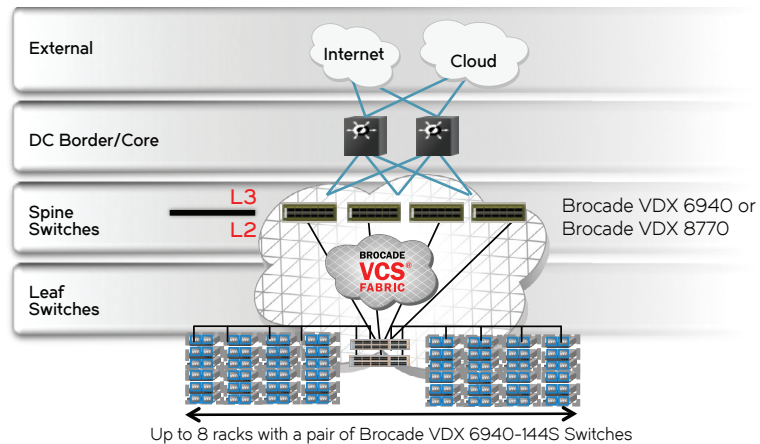

Figure 3: The Brocade VDX 6940-144S Switch for middle-of-row architecture.

### Cloud and Big Data Environments

Brocade VDX 6940 Switches deliver optimized buffer and latency and high performance to enable greater cross-sectional bandwidth for east-west traffic—exactly what cloud workloads demand. These switches offer the flexibility needed to scale-out networks, deliver intelligence to more effectively manage VM mobility, as well as provide an SDN-enabled and programmable infrastructure. Brocade VDX 6940 Switches also offer an advanced feature set that non-virtual and Big Data environments require. With 10/40/100 GbE options for designing oversubscribed or non-oversubscribed networks, high throughput, and optimized buffer and latency, it is an ideal switch for Big Data applications. Together with Brocade VCS Fabric technology, Brocade VDX 6940 Switches can simplify network design and operations for both cloud and Big Data network fabrics.

### High Performance for Data Centers

As data centers virtualize more of their servers and VM density per server increases, organizations will require higher bandwidth connectivity to support the explosion of data and application processing. With 40 GbE and 10 GbE options, Brocade VDX 6940 Switches deliver the high-performance computing needed to keep up with the demands of a virtualized data center, allowing organizations to reduce network congestion, improve application performance, and meet the capacity required by 10 GbE servers. The 40 GbE uplinks can easily aggregate high-bandwidth traffic and reduce bottlenecks that occur when aggregating multiple 10 GbE connections, keeping data center networks working at peak performance.

Brocade VDX 6940 Switches also help maximize network utilization with hardware-based Brocade ISL Trunking. Organizations can create a 120 GbE Brocade ISL trunk by utilizing three 40 GbE ports. The Brocade ISL trunk is automatically formed between two Brocade VDX 6940 Switches when they are linked together, allowing traffic to be equally distributed among all ports. This increases link efficiency and limits traffic disruptions, especially during high-traffic times.

## Dedicated Networks for IP Storage

Building a dedicated network for IP storage is considered a best practice among today's enterprises. This approach to IP storage networks helps ensure independent administrative control and operation, as well as a tight coupling of the application, compute, storage, and network. It allows enterprises to effectively and reliably support ever-growing applications and workloads while improving service-level guarantees, containing failure domains, and reducing security risks.

Whether building a next-generation storage network for server virtualization, business applications, replication, or backup and recovery, organizations need a solution that not only performs, but also provides high availability, fault tolerance, and the ability to expand over time. Brocade VDX switches deliver that performance, resiliency, and scale via patented load balancing and multipathing—cutting-edge technologies leveraged from a long heritage of Brocade Fibre Channel solutions. Self-provisioning and self-healing, Brocade VDX switches offer unmatched simplicity and automation, minimizing the learning curve and ongoing operational costs for storage administrators. Brocade VDX 6940 Switches can facilitate an optimal IP storage network by delivering a fabric-based network architecture to manage the network and storage holistically. At the same time, Brocade Network Advisor provides organizations with unified management, network visibility, and insight across all of their storage networks, including dedicated IP storage networks.

## Optimized Packet Buffer and Latency for Better Application Performance

Brocade VDX 6940 Switches offer a unique balance between two conflicting attributes—buffer and latency. Niche products with very high buffer often suffer from high latency, and products with ultra-low latency are not a good fit for data centers with bursty traffic. Brocade VDX 6940 Switches, with a purpose-built data center chip, excel in optimizing buffer and latency to deliver better application performance. These switches deliver 700 ns any-port-to-any-port latency. In addition, they offer an industry-leading 24 MB deep buffer. This provides the buffering capacity to handle increases in traffic, especially during peak times when ports are congested, allowing traffic to be distributed across the ports. Brocade VDX 6940 Switches also feature a single ASIC design, instead of multiple ASIC designs commonly found in other switches. This improves performance since all ports communicate via the one ASIC.

## Brocade VCS Fabric Technology

Brocade VCS fabrics running on the Brocade VDX family of switches allow organizations to create data center networks that just work. Together, these technologies provide unmatched automation, efficiency, and elasticity in support of the most demanding workloads, such as rich media and mission-critical applications, particularly in highly dynamic cloud environments. To learn more about Brocade VCS Fabric technology, visit [www.brocade.com/vcs](http://www.brocade.com/vcs).

## Unmatched Simplicity and Automation

Brocade VDX 6940 Switches, in conjunction with Brocade VCS Fabric technology, streamline configuration and management, maximize efficiency, and create a more automated and reliable network, especially in highly virtualized environments. Brocade VCS Fabric technology delivers unmatched automation, efficiency, and resilience compared to traditional architectures and competitive fabric offerings. It delivers higher throughput and lower latency for the server-to-server (east-west) traffic patterns that are now dominating virtualized data centers. In changing how networks are architected, VCS fabrics deliver many benefits that fit the needs of evolving environments.

## Fast, Easy Deployment and Configuration

Brocade VCS Fabric technology helps streamline network operations and speed deployment with embedded features that enable automatic configuration and management. These features include:

- **Brocade VCS Logical Chassis:** Brocade VCS Logical Chassis enables organizations to manage an entire VCS fabric as a single switch, upgrade software across the fabric with one command, and centralize monitoring and troubleshooting to enhance the overall availability and reliability of the network. Fabric-level REST APIs allow higher-level management frameworks to provide efficient orchestration of VCS fabrics within a cloud context.

The single point of management eliminates the need to manually configure and manage each switch, simplifying management, lowering operational costs, and reducing configuration errors with the ability to push software upgrades across the fabric with a single command, accelerating deployment. VCS Logical Chassis also provides a single view of the fabric for easy monitoring and troubleshooting, minimizing the time to repair network issues. For more information about VCS Logical Chassis, read the white paper [An Overview of Brocade VCS Logical Chassis](#).

- **Self-forming and self-healing fabric:** Configuration is simplified with self-forming fabrics. As additional switches are added, they inherit the configuration of the fabric, allowing the network to scale out with ease. Configuration and device information is always shared among all Brocade VDX switches, allowing fabric nodes to be added or removed, and physical or virtual servers to be relocated—without the fabric requiring manual reconfiguration. In addition, fabrics are self-healing, increasing network resiliency. The fabric redirects traffic in case a link fails, helping to ensure uninterrupted traffic flow and prevent data loss.
- **Zero-touch provisioning and zero-touch scale-out:** Zero-touch provisioning enables simple, rapid deployment. Provided natively in Brocade VDX switches through VCS Fabric technology, this feature enables installation, automatic software download, and configuration without user intervention.

Brocade VDX switches are preconfigured so that newly deployed switches require only power and a network connection to become part of the fabric. RBridge-ID, VCS-ID, and other VCS fabric parameters are automatically assigned. In addition, Inter-Switch Links (ISLs) automatically form between all new and existing switches in the fabric. By eliminating manual processes, this installation method greatly simplifies scale-out architecture.

Zero-touch provisioning facilitates zero-touch scale-out. With automatic configuration of VCS fabric parameters, self-forming trunks, and logical chassis, network engineers can add, move, and remove network Brocade VDX switches without having to add or delete network configurations. This helps organizations contain costs while increasing reliability and speed when deploying clouds and data centers.

- **A reliable foundation for software-defined networks:** The Brocade VDX 6940 is hardware-enabled with the flexibility to support emerging SDN protocols, including VXLAN/NVGRE. VCS Logical Chassis technology and northbound APIs with fabric- and node-level orchestration capabilities provide operationally scalable management and integration with data center orchestration frameworks such as OpenStack. For more information, read the white paper [Brocade VCS Fabrics: The Foundation for Software-Defined Networks](#).

### In-Service Software Upgrades

The Brocade VDX 6940 delivers a highly efficient In-Service Software Upgrade (ISSU) by leveraging a software model that uses a dual-OS infrastructure on a multi-core CPU. This enables data center administrators to deliver enterprise-class business continuity on fixed switches during a software upgrade/downgrade process. This software change process is non-disruptive to Layer 2, Layer 3, Fibre Channel, and Fibre Channel over Ethernet (FCoE) traffic. Moreover, the ISSU implementation is hardware-optimized, thus reducing the time it takes to complete the upgrade/downgrade process.

### Maximum Efficiency and Resiliency

Brocade VCS Fabric technology creates a more efficient and resilient network with a flat-meshed Layer 2 topology that delivers the high performance and high reliability required by data centers. Organizations gain a more flexible network that helps them rapidly adapt to changing business conditions and traffic patterns.

### Optimized East-West Traffic

Traditional data centers are architected with a rigid, three-tier tree topology optimized for the north-south traffic flow of client-server computing environments, compromising performance, increasing latency, and creating bottlenecks. With the increased prevalence of virtualization and distributed applications, data center network traffic is now predominantly east-west or server-server. The VCS fabric was specifically designed and optimized to address these traffic patterns by moving traffic through any of the active paths and avoiding the multiple hops required in other tiered topologies.

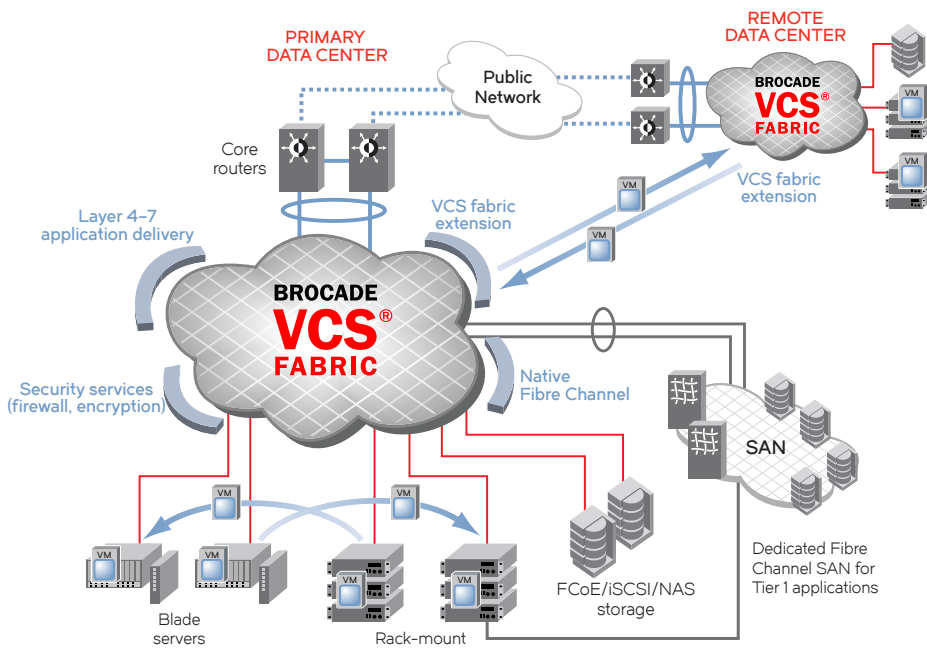

**Figure 4:** Brocade VCS Fabric technology simplifies the network architecture, enables unified storage connectivity, improves VM mobility, and allows the seamless insertion of services.

**Multitenant Cloud Data Centers**

In addition, public and private cloud providers need to deploy and support distributed virtualized workloads quickly, securely, and in a scalable manner on a per-tenant basis. Traditional VLANs can be used for this purpose up to a point, but limitations on VLAN ID scale and the complexity of configuring large numbers of VLANs restrict their usefulness in larger data centers. The VCS Virtual Fabric feature of Brocade VCS Fabric technology is designed to address the scalability restrictions of traditional VLANs used for multitenant segmentation. It provides native secure multitenant support for both physical and virtual application deployments within and across VCS fabrics. Managed centrally through Brocade VCS Logical Chassis, the VCS Virtual Fabric feature simplifies and accelerates application deployment, and ensures policy consistency for each tenant

regardless of how application components are distributed across the data center. VXLAN and VRF Lite are other options for network segmentation. To learn more, read *Multitenancy Options in Brocade VCS Fabrics*.

**Virtual Fabric Extension**

Virtual fabric extension permits a Layer 2 connection between multiple VCS fabrics interconnected over a Layer 3 cloud. This allows VLANs, service VLANs, and transport VLANs to span across multiple VCS fabrics.

Virtual fabric extension is achieved through VXLAN encapsulation of Layer 2 frames, which are tunneled across VCS fabrics over a Layer 3 cloud. This feature does not require NSX or multicast to be running in Layer 3 clouds interconnecting VCS fabrics and any other controller. With virtual fabric extension, service providers and enterprises can extend

Layer 2 traffic across multiple virtual fabrics within a single data center, or across multiple data centers, while still maintaining multitenant segmentation. Moreover, they can avoid installing costly dedicated WAN links or MPLS/GRE underlay, as virtual fabric extension requires only simple Layer 3 IP connectivity across sites.

**Multiple Load-Balanced Paths at Layers 1-3**

Brocade VCS Fabric technology enables highly elastic domains with extremely efficient load balancing in Layers 1-3. Innovative Brocade ISL Trunking load balances traffic across all the links in a trunk for improved performance at Layer 1. In Layer 2, Equal Cost Multi-Path (ECMP) uses all available network bandwidth, allowing all links to be fully active and utilized. In the event of a failure, traffic is automatically routed to the closest path, providing higher resilience and greater application uptime. In Layer 3, the fabric automatically load balances all flows among a number of Layer 3 instances that collectively act as a single Layer 3 gateway. Multilayer multipathing helps improve network utilization, reduce latency, and increase overall network performance. Read the white paper *Setting a New Standard for Network Efficiency with VCS Fabric Multilayer Multipathing Capabilities* to learn more.

**Optimized for Virtualization**

Brocade VCS Fabric technology offers unique features to support virtualized server and storage environments, and enable the transition to cloud computing (see Figure 4):

- **Brocade VCS Gateway for NSX:** Brocade VCS Gateway for NSX is a solution that unifies both virtual and physical infrastructure for a seamless transition to cloud environments. By

unifying the best of both worlds—physical and virtual—Brocade VCS Gateway for NSX allows physical devices to connect to virtual devices.

Brocade VCS Gateway is integrated with VMware NSX, enabling the entire VCS fabric to function as a VXLAN gateway and eliminating the need for specific network placement. As such, the NSX Controller sees the VCS fabric as a single logical gateway, thereby simplifying management and providing resiliency. Administrators can leverage existing infrastructure while gaining the benefits of VXLAN to support multitenancy and large-scale deployments of distributed applications.

In addition, Brocade VCS Gateway for NSX is integrated with the VMware NSX Controller. It offers the benefits of agility with self-service provisioning, flexible network architecture, scale-out modularity with VCS fabric, multitenancy, and an easily managed unified solution for physical and virtual assets.

- **Zero-touch VM discovery:** Brocade VM-Aware Network Automation eliminates the manual configuration of port profiles when a VM is added to the fabric or moved, providing an additional level of automation. The VCS fabric directly communicates with VMware vCenter, automatically downloading all port profile information and the associated MAC address, and distributes the VM-specific information to all switches within the fabric. When the VM moves, no additional configuration is required.
- **Automatic Migration of Port Profiles:** During a VM migration, the destination network switch ports must be configured to ensure that the VM traffic experiences consistent policies

and configurations. With the Brocade Automatic Migration of Port Profiles (AMPP) feature, the VM policies and networking policies follow the VM within the VCS fabric. As a VM migrates, the destination port in the fabric learns of the MAC address move and automatically activates the port profile configuration within a single fabric or across separate fabrics. AMPP is hypervisor-agnostic and can be used with various hypervisors.

### Flexible Design Meets Data Center Needs

Brocade VDX 6940 Switches are designed to connect data centers in multiple ways to meet individual design requirements. This flexible design provides investment protection, giving organizations a single switch that can support varying data center requirements. The following features help organizations meet their evolving needs:

- **10/40/100 GbE uplinks:** The 40 GbE QSFP+ ports offer the flexibility to expand and interconnect the network infrastructure intelligently and efficiently while reducing bottlenecks. The switches offer the option to separate each 40 GbE uplink into four 10 GbE uplinks via breakout cables. As capacity and need increase, organizations can simply revert to 40 GbE when ready.
- **Ports on Demand:** Ports on Demand (PoD) enables organizations to activate 12 additional ports. They can purchase the number of ports that they currently need and seamlessly scale up later by simply applying a software license. This flexible and cost-efficient “pay-as-you-grow” licensing model solves scalability challenges by allocating IT resources as needed.

### Advanced Storage Support

Brocade VDX 6940 Switches provide advanced storage support with multiple storage connectivity options, including FCoE, iSCSI, and NAS. They also feature Data Center Bridging (DCB), which enables the reliable exchange of storage traffic over the LAN, eliminating packet loss when network congestion occurs and allocating bandwidth as needed to keep the network running efficiently. The switches offer NAS Auto QoS intelligence to prioritize delay-sensitive IP storage traffic within the fabric and help ensure consistent performance while decreasing latency.

### Ease-of-Use Augmented by Brocade Network Advisor

Brocade Network Advisor is an easy-to-use network management platform for advanced management of Brocade VCS fabrics and Brocade VDX switches across the entire network lifecycle. Organizations can use Brocade Network Advisor to manage a VCS fabric as a single entity or to drill down to individual Brocade VDX switches for fault, inventory, or performance management—and to manage multiple VCS fabrics in parallel.

Brocade Network Advisor also provides simplified management of AMPP configurations, and integrity checks can be performed across physical Brocade VDX configurations—either in the same fabric or across different VCS fabrics. In addition, Brocade Network Advisor enables VM-level monitoring and can help identify top-talker applications leveraging sFlow across the fabric. Finally, Brocade Network Advisor provides VCS fabric diagnostics, including visualization of VCS fabric traffic paths and network latency monitoring that enables fault isolation via hop-by-hop inspection. For details, visit [www.brocade.com/management](http://www.brocade.com/management).

## **Programming The On-Demand Data Center™**

Organizations eager to capitalize on the benefits of virtual environments, namely increased automation, need networks that can be easily and quickly deployed. This requires network tools and infrastructure that are open and able to change rapidly with their businesses. Brocade supports programmatic solutions and DevOps tools that allow a customized approach to deploying, operating, and interacting with the network. These solutions offer a new level of simplicity, agility, and rapid, automatic deployment, enabling data centers to evolve to meet new technology requirements.

Brocade VDX switches provide OpenStack Neutron ML2 support and fabric-level, programmable REST APIs with a YANG data model to enable integration with third-party and in-house network automation and cloud management tools. Support for Puppet and Python scripting offers choice and more effective configuration management. These programmability options help automate, simplify, reduce human error, and streamline the process while reducing costs. The tools also help drive productivity by enabling rapid application deployment for enterprises, and increase profitability by streamlining the tenant provisioning process and making networks more intelligent and flexible for cloud providers.

VCS fabrics provide support for OpenFlow 1.3, an industry-standard SDN communications protocol, allowing operators to address complex network behavior, optimize performance, and leverage a richer set of capabilities.

OpenFlow 1.3 integrated with Brocade VDX switches provides the features, performance, and operational efficiency that data centers need today and tomorrow.

## **Brocade Global Services**

Brocade Global Services has the expertise to help organizations build scalable, and efficient cloud infrastructures. Leveraging 15 years of expertise in storage, networking, and virtualization, Brocade Global Services delivers world-class professional services, technical support, and education services, enabling organizations to maximize their Brocade investments, accelerate new technology deployments, and optimize the performance of networking infrastructures.

## **Affordable Acquisition Options**

Brocade Capital Solutions helps organizations easily address their IT requirements by offering flexible network acquisition and support alternatives. Organizations can select from purchase, lease, Brocade Network Subscription, and Brocade Subscription Plus options to align network acquisition with their unique capital requirements and risk profiles. To learn more, visit [www.Brocade.com/CapitalSolutions](http://www.Brocade.com/CapitalSolutions).

## **Maximizing Investments**

To help optimize technology investments, Brocade and its partners offer complete solutions that include professional services, technical support, and education. For more information, contact a Brocade sales partner or visit [www.brocade.com](http://www.brocade.com).



## Brocade VDX 6940-36Q and 6940-144S Feature Overview

Overview	Brocade VDX 6940-36Q	Brocade VDX 6940-144S
Form factor	1U	2U
Switching bandwidth (data rate, full duplex)	2.88 Tbps	2.88 Tbps
Switch performance	2.16 Bpps	2.16 Bpps
Port-to-port latency	700 ns	700 ns
Dimensions and weight	Width: 44 cm (17.32 in.) Height: 4.4 cm (1.73 in.) Depth: 43.8 cm (17.22 in.) Weight: 8.9 kg (19.6 lb) without media; 10.1 kg (22.3 lb) with media	Width: 44 cm (17.32 in.) Height: 8.7 cm (3.41 in.) Depth: 48.5 cm (19.1 in.) Weight: 15.46 kg (34.1 lb) empty; 17.32 kg (38.2 lb) with media
10 GbE SFP+ ports	144 10 GbE ports using breakout cables	96 fixed 10 GbE ports and additional 48 10 GbE ports with breakout cables
1 GbE SFP	0	96
1/10 GBASE-T	0	0
40 GbE QSFP+	36	12
100 GbE QSFP28	0	4
40 GbE Ports on Demand (PoD)	24, 36	6, 12
10 GbE Ports on Demand (PoD)	N/A	64, 80, 96
Power supplies	Two internal, redundant, field-replaceable, load-sharing AC/DC power supplies	Two internal, redundant, field-replaceable, load-sharing AC/DC power supplies
Cooling fans	5 field-replaceable fan (FRUs); each fan FRU has 2 fans	4 field-replaceable fans (FRUs); each fan FRU has 1 fan
Airflow	Rear-to-front or front-to-rear airflow	Rear-to-front or front-to-rear airflow

## Brocade VDX 6940-36Q and 6940-144S Feature Overview

### Scalability Information\*

Connector options	Out-of-band Ethernet management: RJ-45 (fixed) Console management: RJ45 to RS-232 (fixed) Firmware and diagnostic: USB
Maximum VLANs	4,000—few reserved (~15)
Maximum MAC addresses	112,000 (L2 MACs); fabric-wide 256,000 (CML)
Maximum port profiles (AMPP)	512
Maximum members in a standard LAG	16
Maximum per-port priority pause level	8
Maximum switches in a VCS fabric	48
Maximum ECMP paths in a VCS fabric	16
Maximum trunk members for VCS fabric ports	16
Maximum LAG groups in a VCS fabric	1,000

\* Please refer to the latest version of the release notes for the most up-to-date scalability numbers.

## Brocade VDX 6940-36Q and 6940-144S Specifications

### Scalability Information\* *continued*

Maximum switches across which a vLAG can span	8
Maximum members in a vLAG	64
Maximum jumbo frame size	9,216 bytes
Queues per port	8
DCB Priority Flow Control (PFC) classes	8
Maximum ACLs	10,000
Maximum ARP entries	84,000
Maximum IPv4 unicast routes	12,000
Maximum IPv6 unicast routes	3,000
DCB Priority Flow Control (PFC) classes	8
HA/ISSU	ISSU fully supported

### General

Operating system	Brocade Network OS, a modular operating system	
Layer 2 switching features	<ul style="list-style-type: none"> <li>• Address Resolution Protocol (ARP) RFC 826</li> <li>• High availability/In-Service Software Upgrade—hardware-enabled</li> <li>• IGMP v1/v2 Snooping</li> <li>• MAC Learning and Aging</li> <li>• Link Aggregation Control Protocol (LACP) IEEE 802.3ad/802.1AX</li> <li>• Virtual Local Area Networks (VLANs)</li> <li>• VLAN Encapsulation 802.1Q</li> <li>• Private VLANs</li> <li>• Edge Loop Detection (ELD)</li> </ul>	<ul style="list-style-type: none"> <li>• Per-VLAN Spanning Tree (PVST+ /PVRST+)</li> <li>• Rapid Spanning Tree Protocol (RSTP) 802.1w</li> <li>• Multiple Spanning Tree Protocol (MSTP) 802.1s</li> <li>• STP PortFast, BPDU Guard, BPDU Filter</li> <li>• STP Root Guard</li> <li>• Layer 2 Access Control Lists (ACLs)</li> <li>• Pause Frames 802.3x</li> <li>• Uni-Directional Link Detection (UDLD)</li> </ul>
Layer 3 switching features	<ul style="list-style-type: none"> <li>• Border Gateway Protocol (BGP4+)</li> <li>• DHCP Helper</li> <li>• Layer 3 ACLs</li> <li>• Multicast: PIM-SM, IGMPv2</li> <li>• OSPF</li> <li>• Static routes</li> <li>• IPv4/v6 ACL</li> <li>• Policy-Based Routing (PBR)</li> <li>• Bidirectional Forwarding Detection (BFD)</li> <li>• 32-way ECMP</li> </ul>	<ul style="list-style-type: none"> <li>• VRF Lite</li> <li>• VRF-aware OSPF, BGP, VRRP, static routes</li> <li>• VRRP v2 and v3</li> <li>• IPv4/IPv6 dual stack</li> <li>• IPv6 ACL packet filtering</li> <li>• IPv6 routing</li> <li>• Wire-speed routing for IPv4 and IPv6 using any routing protocol</li> </ul>

\* Please refer to the latest version of the release notes for the most up-to-date scalability numbers.

## Brocade VDX 6940-36Q and 6940-144S Specifications *(Continued)*

### General *continued*

Brocade VCS Fabric technology features	<ul style="list-style-type: none"> <li>• Automatic Fabric Formation</li> <li>• DHCP Option 66/67 (Auto Fabric Provisioning)</li> <li>• Distributed Configuration Management</li> <li>• Distributed Fabric Services</li> </ul>	<ul style="list-style-type: none"> <li>• Switch Beaconing</li> <li>• Transparent Interconnection of Lots of Links (TRILL)</li> <li>• Transparent LAN Services</li> <li>• Virtual Link Aggregation Group (vLAG) spanning</li> <li>• VRRP-E</li> <li>• 16-way ECMP</li> <li>• Zero-touch provisioning</li> <li>• Fabric virtual gateway</li> </ul>
Multitenancy and virtualization features	<ul style="list-style-type: none"> <li>• TRILL FGL-based VCS Virtual Fabric feature</li> <li>• Brocade VCS Gateway for NSX with VMware NSX Orchestration</li> <li>• Virtual fabric extension</li> </ul>	<ul style="list-style-type: none"> <li>• Automatic Migration of Port Profiles (AMPP)</li> <li>• VM-Aware Network Automation</li> <li>• BFD for virtual fabric extension</li> </ul>
DCB features	<ul style="list-style-type: none"> <li>• Priority-based Flow Control (PFC) 802.1Qbb</li> <li>• Enhanced Transmission Selection (ETS) 802.1Qaz</li> <li>• Manual configuration of lossless queues for protocols other than FCoE and iSCSI</li> </ul>	<ul style="list-style-type: none"> <li>• Data Center Bridging eXchange (DCBX)</li> <li>• DCBX Application Type-Length-Value (TLV) for FCoE and iSCSI</li> </ul>
Fibre Channel/FCoE features (Requires FCoE license)	<ul style="list-style-type: none"> <li>• Multihop Fibre Channel over Ethernet (FCoE); requires Brocade VCS Fabric technology</li> <li>• FC-BB5 compliant Fibre Channel Forwarder (FCF)</li> <li>• Native FCoE forwarding</li> <li>• FCoE to Fibre Channel Bridging</li> <li>• FCoE on Brocade VDX 6940</li> <li>• FCoE on QSFP+ port</li> <li>• Flex Ports, allowing direct and SAN connectivity of Fibre Channel targets</li> <li>• Multi-hop Access Gateway Support</li> </ul>	<ul style="list-style-type: none"> <li>• End-to-end FCoE (initiator to target)</li> <li>• FCoE Initialization Protocol (FIP) v1 support for FCoE device login and initialization</li> <li>• Name Server-based zoning</li> <li>• Supports connectivity to FIP Snooping Bridge (FSB) device</li> <li>• FCoE traffic over standard LAG</li> <li>• Interface Binding</li> <li>• Logical SANs</li> </ul>
IP storage	<ul style="list-style-type: none"> <li>• Auto QoS (automatic prioritization of IP storage traffic)</li> </ul>	
High availability	<ul style="list-style-type: none"> <li>• ISSU L2 and L3</li> <li>• BFD</li> <li>• OSPF v2/v3</li> <li>• OSPF3-NSR</li> <li>• BGP4</li> <li>• BGP4-GR</li> </ul>	
Quality of Service (QoS)	<ul style="list-style-type: none"> <li>• ACL-based QoS</li> <li>• Eight priority levels for QoS</li> <li>• Class of Service (CoS) IEEE 802.1p</li> <li>• DSCP Trust</li> <li>• DSCP to Traffic Class Mutation</li> <li>• DSCP to CoS Mutation</li> <li>• DSCP to DSCP Mutation</li> <li>• Random Early Discard</li> </ul>	<ul style="list-style-type: none"> <li>• Per-port QoS configuration</li> <li>• ACL-based Rate Limit</li> <li>• Dual-rate three color token bucket</li> <li>• ACL-based remarking of CoS/DSCP/Precedence</li> <li>• ACL-based sFlow</li> <li>• Scheduling: Strict Priority (SP), Deficit Weighted Round Robin (DWRR), Hybrid Scheduling (Hybrid)</li> <li>• Queue-based Shaping</li> <li>• Flow-based QoS</li> </ul>
Switch health monitoring	Brocade Fabric Watch monitoring and notification	

\* Please refer to the latest version of the release notes for the most up-to-date scalability numbers.

## Brocade VDX 6940-36Q and 6940-144S Specifications (Continued)

### Management

Management and monitoring	<ul style="list-style-type: none"> <li>• IPv4/IPv6 management</li> <li>• Industry-standard Command Line Interface (CLI)</li> <li>• Netconf API</li> <li>• REST API with YANG data model</li> <li>• Brocade VCS Plugin for OpenStack</li> <li>• Link Layer Discovery Protocol (LLDP) IEEE 802.1AB</li> <li>• Logical chassis management</li> <li>• MIB II RFC 1213 MIB</li> <li>• Switch Beaconing</li> <li>• Management VRF</li> <li>• Switched Port Analyzer (SPAN)</li> <li>• Telnet</li> </ul>	<ul style="list-style-type: none"> <li>• SNMP v1, v2C, v3</li> <li>• sFlow RFC 3176</li> <li>• Out-of-band management</li> <li>• Remote SPAN (RSPAN)</li> <li>• RMON-1, RMON-2</li> <li>• NTP</li> <li>• Management Access Control Lists (ACLs)</li> <li>• Role-Based Access Control (RBAC)</li> <li>• Range CLI support</li> <li>• UDLD</li> <li>• OpenStack Neutron ML2 plugin</li> <li>• Python</li> <li>• Puppet</li> </ul>
Security	<ul style="list-style-type: none"> <li>• Port-based Network Access Control 802.1X</li> <li>• RADIUS (AAA)</li> <li>• TACACS+</li> <li>• Secure Shell (SSHv2)</li> <li>• BPDU Drop</li> <li>• Lightweight Directory Access Protocol (LDAP)</li> <li>• Secure Copy Protocol</li> </ul>	
Software-Defined Networking (SDN) and programmability	<ul style="list-style-type: none"> <li>• OpenFlow 1.3</li> <li>• VXLAN Gateway</li> <li>• REST API with YANG data model</li> <li>• Puppet</li> <li>• Python</li> </ul>	
<b>Mechanical</b>		
Enclosure	Front-to-rear, rear-to-front airflow; 1U (6940-36Q) and 2U (6940-144S), 19-inch EIA-compliant; power from non-port side	
<b>Environmental</b>	<b>Brocade VDX 6940-36Q</b>	<b>Brocade VDX 6940-144S</b>
Temperature	Operating: 0°C to 40°C (32°F to 104°F) Non-operating and storage: -25°C to 70°C (-13°F to 158°F)	Operating: 0°C to 40°C (32°F to 104°F) Non-operating and storage: -25°C to 70°C (-13°F to 158°F)
Humidity	Operating: 5% to 93% at 50°C (122°F) Non-operating and storage: 10% to 95% at 60°C (140°F)	Operating: 5% to 93% at 50°C (122°F) Non-operating and storage: 10% to 95% at 60°C (140°F)
Altitude	Operating: 0 to 3,000 m (9,842 ft.) Non-operating and storage: 0 to 12,000 m (39,370 ft.)	Operating: 0 to 3,000 m (9,842 ft.) Non-operating and storage: 0 to 12,000 m (39,370 ft.)
Shock	Operating: 15 G, 11 ms, half-sine wave Non-operating and storage: 33 G, 11 ms, half-sine wave, 5/ea axis, and 33 G 6 ms, trapezoidal, 1/ea axis	Operating: 15 G, 11 ms, half-sine wave Non-operating and storage: 33 G, 11 ms, half-sine wave, 5/ea axis, and 33 G 6 ms, trapezoidal, 1/ea axis
Vibration	Operating: 1 G sine, 0.5 gms random, 5 to 500 Hz Non-operating and storage: 2.4 G sine, 1.1 gms random, 5 to 500 Hz	Operating: 1 G sine, 0.5 gms random, 5 to 500 Hz Non-operating and storage: 2.4 G sine, 1.1 gms random, 5 to 500 Hz
Airflow	Maximum: 159 cmh (94 cfm) Minimum: 65 cmh (38 cfm)	Maximum: 370 cmh (218 cfm) Minimum: 95 cmh (56 cfm)

## Brocade VDX 6940-36Q and 6940-144S Specifications (Continued)

### Power

Power supplies	Two internal, redundant, field-replaceable, load-sharing power supplies
Power inlet	C13
Input voltage	100 to 240 V or 48 V DC
Input line frequency	50 to 60 Hz

### Power

	Brocade VDX 6940-36Q	Brocade VDX 6940-144S
Inrush current	30 A peak at cold start and 50 A peak at warm start for <10 ms, 10 A peak for cycles 10 ms to 150 ms, <7 A peak for >150 ms	40 A peak at either cold or warm start <10 ms, 10 A peak for cycles 10 ms to 150 ms, <7 A peak for >150 ms
Maximum current	6 A at 100 VAC/7 A at 90 VAC	6 A at 100 VAC/7 A at 85 VAC
Typical power consumption	At 100 VAC 2.18 A, 215 W, 733.81 BTU/hr At 200 VAC 1.12 A, 212 W, 723.57 BTU/hr Input current calculated with 1 PSU; watts and BTU/hour with 2 PSUs	At 100 VAC 3.288 A, 327 W, 1,116 BTU/hr At 200 VAC 1.639 A, 321 W, 1,095 BTU/hr Input current calculated with 1 PSU; watts and BTU/hour with 2 PSUs
Maximum power consumption	At 100 VAC 2.84 A, 282 W, 962.5 BTU/hr At 200 VAC 1.44 A, 276 W, 942 BTU/hr Input current calculated with 1 PSU; watts and BTU/hour with 2 PSUs	At 100 VAC 2.706 A, 512 W, 1,747 BTU/hr At 200 VAC 1.375 A, 500 W, 1,706 BTU/hr Input current calculated with 1 PSU; watts and BTU/hour with 2 PSUs

### Safety Compliance

CAN/CSA C22.2 No. 60950-1-07 including A1 / UL 60950-1-07, Ed. 2 including A1 CAN/CSA-C22.2 No. 60950-1 Second Edition EN 60950-1 Second Edition +A1/A12	IEC 60950-1 Second Edition +A1 GB 4943.1-2011 and GB9254-2008 CNS14336-1(99) CSA/NRTL Certification
---	--

### EMC

FCC Class A ICES-003 Class A VCCI-Class A CE	C-Tick BSMI KCC Class A
---	-------------------------------

### Immunity

EN55024
---------

### Environmental Regulatory Compliance

RoHS-6 (with lead exemption) Directive 2002/95/EC NEBS-Compliant
---

### Standards Compliance

<p>Brocade VDX 6940 products conform to the following Ethernet standards:</p> <ul style="list-style-type: none"> <li>• IEEE 802.1D Spanning Tree Protocol</li> <li>• IEEE 802.1s Multiple Spanning Tree</li> <li>• IEEE 802.1w Rapid Reconfiguration of Spanning Tree Protocol</li> <li>• IEEE 802.3 Ethernet</li> <li>• IEEE 802.3ad Link Aggregation with LACP</li> <li>• IEEE 802.3ae 10G Ethernet</li> <li>• IEEE 802.1Q VLAN Tagging</li> <li>• IEEE 802.1p Class of Service Prioritization and Tagging</li> <li>• IEEE 802.1v VLAN Classification by Protocol and Port</li> </ul>
---

## Brocade VDX 6940-36Q and 6940-144S Specifications *(Continued)*

### Standards Compliance *continued*

- IEEE 802.1AB Link Layer Discovery Protocol (LLDP)
- IEEE 802.3x Flow Control (Pause Frames)
- IEEE 802.3ab 1000BASE-T
- IEEE 802.3z 1000BASE-X

The following draft versions of the Data Center Bridging (DCB) and Fibre Channel over Ethernet (FCoE) standards are also supported on the Brocade VDX 6940:

- IEEE 802.1Qbb Priority-based Flow Control
- IEEE 802.1Qaz Enhanced Transmission Selection
- IEEE 802.1 DCB Capability Exchange Protocol (Proposed under the DCB Task Group of IEEE 802.1 Working Group)
- FC-BB-5 FCoE (Rev 2.0)

### RFC Support

RFC 768	User Datagram Protocol (UDP)
RFC 783	TFTP Protocol (revision 2)
RFC 791	Internet Protocol (IP)
RFC 792	Internet Control Message Protocol (ICMP)
RFC 793	Transmission Control Protocol (TCP)
RFC 826	ARP
RFC 854	Telnet Protocol Specification
RFC 894	A Standard for the Transmission of IP Datagram over Ethernet Networks
RFC 1027	Using ARP to Implement Transparent Subnet Gateways (Proxy ARP)
RFC 959	FTP
RFC 1112	IGMP v1
RFC 1157	Simple Network Management Protocol (SNMP) v1 and v2
RFC 1305	Network Time Protocol (NTP) Version 3
RFC 1492	TACACS+
RFC 1519	Classless Interdomain Routing (CIDR)
RFC 1584	Multicast Extensions to OSPF
RFC 1765	OSPF Database Overflow
RFC 1812	Requirements for IP Version 4 Routers
RFC 1997	BGP Communities Attribute
RFC 2068	HTTP Server
RFC 2131	Dynamic Host Configuration Protocol (DHCP)
RFC 2154	OSPF with Digital Signatures (Password, MD-5)
RFC 2267	Network Ingress Filtering
RFC 2328	OSPF v2 (edge mode)
RFC 2460	Internet Protocol, Version 6 (v6) Specification (on management interface)
RFC 2370	OSPF Opaque Link-State Advertisement (LSA) Option—Partial Support
RFC 2385	Protection of BGP Sessions with the TCP MD5 Signature Option
RFC 2439	BGP Route Flap Damping
RFC 2464	Transmission of IPv6 Packets over Ethernet Networks (on management interface)
RFC 2474	Definition of the Differentiated Services Field in the IPv4 and IPv6 Headers
RFC 2571	An Architecture for Describing SNMP Management Frameworks

## Brocade VDX 6940-36Q and 6940-144S Specifications (Continued)

### RFC Support continued

RFC 2865	Remote Authentication Dial-In User Service (RADIUS)
RFC 3101	The OSPF Not-So-Stubby Area (NSSA) Option
RFC 3176	sFlow
RFC 3137	OSPF Stub Router Advertisement
RFC 3392	Capabilities Advertisement with BGPv4
RFC 3768	VRRP
RFC 4510	Lightweight Directory Access Protocol (LDAP): Technical Specification Road Map
RFC 4271	BGPv4
RFC 4292	IP Forwarding MIB
RFC 4293	Management Information Base for the Internet Protocol (IP)
RFC 3411	An Architecture for Describing SNMP Frameworks
RFC 3412	Message Processing and Dispatching for the SNMP
RFC 3413	Simple Network Management Protocol (SNMP) Applications
RFC 4456	BGP Route Reflection
RFC 4601	Protocol Independent Multicast—Sparse Mode (PIM-SM): Protocol Specification (Revised)
RFC 4893	BGP Support for Four-Octet AS Number Space
RFC 4861/5942	IPv6 Neighbor Discovery
RFC 2462	IPv6 Stateless Address Auto-Configuration
RFC 4443	ICMPv6 (replaces 2463)
RFC 4291	IPv6 Addressing Architecture
RFC 3587	IPv6 Global Unicast Address Format
RFC 2375	IPv6 Multicast Address Assignments
RFC 2711	IPv6 Router Alert Option
RFC 4724	Graceful Restart Mechanism for BGP
RFC 3623	Graceful OSPF Restart—IETF Tools
RFC 5880	Bidirectional Forwarding Detection (BFD)
RFC 5881	Bidirectional Forwarding Detection (BFD) for IPv4 and IPv6 (Single Hop)
RFC 5882	Generic Application of Bidirectional Forwarding Detection (BFD)
RFC 5883	Bidirectional Forwarding Detection (BFD) for Multihop Paths
<b>IPv6 Routing</b>	
RFC 2740	OSPFv3 for IPv6
RFC 2545	Use of BGP-MP Extensions for IPv6
<b>IPv6 Multicast</b>	
RFC 2710	Multicast Listener Discovery (MLD) for IPv6
<b>VRRP/VRRPe</b>	
RFC 5798	VRRP Version 3 for IPv4 and IPv6

## Brocade VDX 6940-36Q and 6940-144S Software License Ordering Information

Software SKU	Description
BR-VDX6940-FCOE	FCoE software license for Brocade VDX 6940
BR-VDX6940-144S-16-10GPOD	16x10 GbE Ports on Demand (PoD) license for Brocade VDX 6940-144S
BR-VDX6940-144S-6X40G-POD	6x40 GbE or 2x100 GbE Ports on Demand (PoD) license for Brocade VDX 6940-144S
BR-VDX6940-36Q-12X40G-POD	12x40 GbE Ports on Demand (PoD) license for Brocade VDX 6940-36Q

## Brocade VDX 6940-36Q and 6940-144S Hardware Ordering Information

Hardware SKU	Description
BR-VDX6940-36Q-AC-F	Brocade VDX 6940-36Q base system with 36 40 GbE QSFP+ ports, AC power supply, non-port-side exhaust airflow
BR-VDX6940-36Q-AC-R	Brocade VDX 6940-36Q base system with 36 40 GbE QSFP+ ports, AC power supply, port-side exhaust airflow
BR-VDX6940-24Q-DC-F	Brocade VDX 6940-36Q base system with 24 40 GbE QSFP+ ports, DC power supply, non-port-side exhaust airflow
BR-VDX6940-24Q-DC-R	Brocade VDX 6940-36Q base system with 24 40 GbE QSFP+ ports, DC power supply, port-side exhaust airflow
BR-VDX6940-24Q-AC-F	Brocade VDX 6940-36Q base system with 24 40 GbE QSFP+ ports, AC power supply, non-port-side exhaust airflow
BR-VDX6940-24Q-AC-R	Brocade VDX 6940-36Q base system with 24 40 GbE QSFP+ ports, AC power supply, port-side exhaust airflow
BR-VDX6940-64S-AC-R	Brocade VDX 6940-144S base system with 64 10 GbE SFP+ ports, AC power supply, port-side exhaust airflow
BR-VDX6940-64S-AC-F	Brocade VDX 6940-144S base system with 64 10 GbE SFP+ ports, AC power supply, non-port-side exhaust airflow
BR-VDX6940-96S-AC-R	Brocade VDX 6940-144S base system with 96 10 GbE SFP+ ports, AC power supply, port-side exhaust airflow
BR-VDX6940-96S-AC-F	Brocade VDX 6940-144S base system with 96 10 GbE SFP+ ports, AC power supply, non-port-side exhaust airflow
BR-VDX6940-144S-AC-R	Brocade VDX 6940-144S base system with 96 10 GbE SFP+ ports and up to 12 40 GbE QSFP+ ports or up to 4 100 GbE QSFP28 ports, AC power supply, port-side exhaust airflow
BR-VDX6940-144S-AC-F	Brocade VDX 6940-144S base system with 96 10 GbE SFP+ ports and up to 12 40 GbE QSFP+ ports or up to 4 100 GbE QSFP28 ports, AC power supply, non-port-side exhaust airflow
BR-VDX6940-64S-DC-F	Brocade VDX 6940-144S base system with 64 10 GbE SFP+ ports, DC power supply, non-port-side exhaust airflow
BR-VDX6940-64S-DC-R	Brocade VDX 6940-144S base system with 64 10 GbE SFP+ ports, DC power supply, port-side exhaust airflow

### Corporate Headquarters

San Jose, CA USA  
T: +1-408-333-8000  
info@brocade.com

### European Headquarters

Geneva, Switzerland  
T: +41-22-799-56-40  
emea-info@brocade.com

### Asia Pacific Headquarters

Singapore  
T: +65-6538-4700  
apac-info@brocade.com



© 2015 Brocade Communications Systems, Inc. All Rights Reserved. 07/15 GA-DS-1902-03

ADX, Brocade, Brocade Assurance, the B-wing symbol, DCX, Fabric OS, HyperEdge, ICX, MLX, MyBrocade, OpenScript, The Effortless Network, VCS, VDX, Vplane, and Vyatta are registered trademarks, and Fabric Vision and vADX are trademarks of Brocade Communications Systems, Inc., in the United States and/or in other countries. Other brands, products, or service names mentioned may be trademarks of others.

Notice: This document is for informational purposes only and does not set forth any warranty, expressed or implied, concerning any equipment, equipment features, or service offered or to be offered by Brocade. Brocade reserves the right to make changes to this document at any time, without notice, and assumes no responsibility for its use. This information document describes features that may not be currently available. Contact a Brocade sales office for information on feature and product availability. Export of technical data contained in this document may require an export license from the United States government.

